



## Packaging Information

### Mechanical Dimensions

DIP-7

Unit: mm(inch)

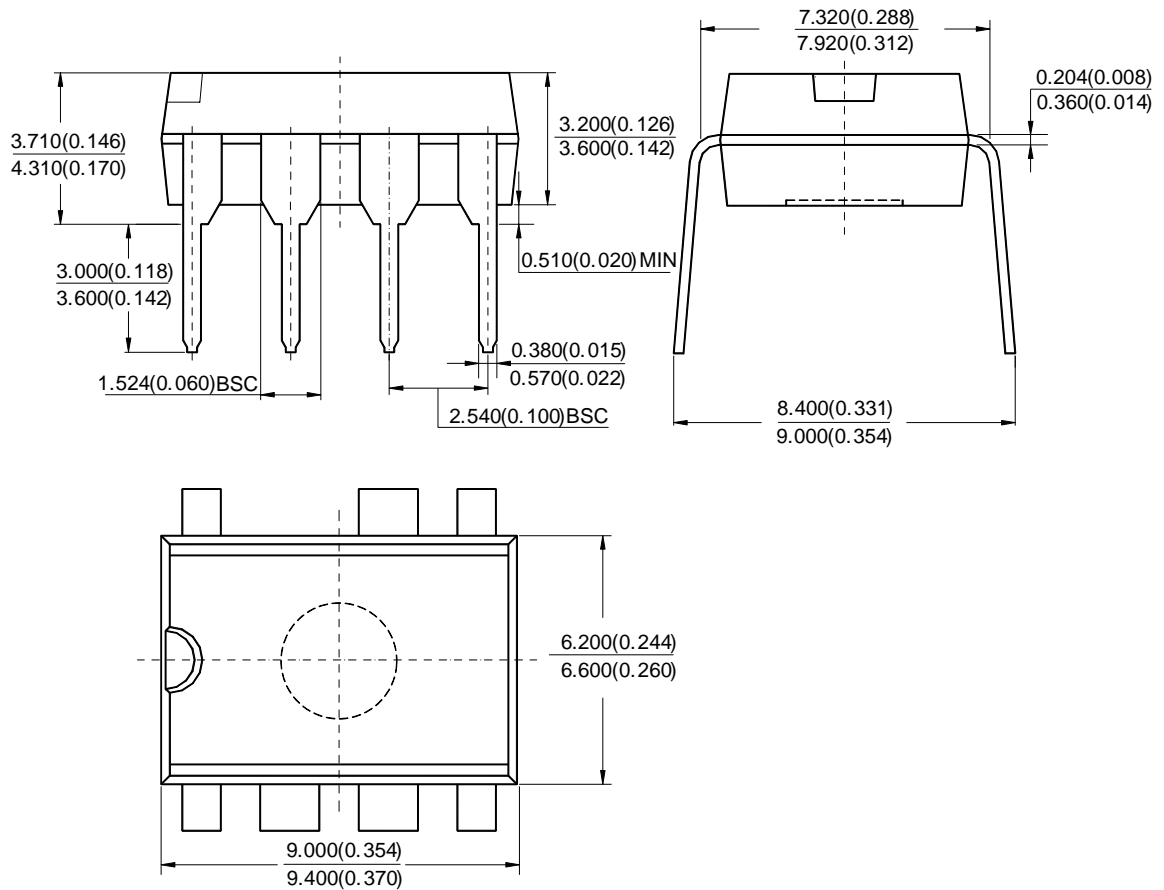

Note: Eject hole, oriented hole and mold mark is optional



---

## Packaging Information

---

### DIP-7

