



Test Report

NO.: AKS0905152020F

Date: May 21, 2009

Page 1 of 7

Customer: Nantong Fujitsu Microelectronic Co., Ltd

Address: No.288, Chongchuan Road, Nantong, Jiangsu, China

Report on the submitted sample said to be

Sample name: SOT23-5

Model: /

Item/Lot No.: /

Material: /

Buyer: /

Supplier: /

Manufacturer: /

Sample received date: May 15, 2009

Testing period: From May 15, 2009 to May 21, 2009

Testing Requested

1. As specified by client, to determine the Lead, Cadmium, Mercury, Hexavalent Chromium, PBB & PBDE content in the submitted sample in accordance with Directive 2002/95/EC (RoHS).
2. As specified by client, to determine the PFOA content in the submitted samples in accordance with POHS.
3. As specified by client, to determine PFOS content in the submitted samples in accordance with Directive 2006/122/EC.
4. As specified by client, to determine the Fluorine, Chlorine, Bromine and Iodine content in the submitted sample.

Testing method:

Testing Item	Pretreatment method	Measuring instrument	MQL
Lead (Pb)	IEC 62321: 2008, section 9/10	ICP-OES	2mg/kg
Cadmium (Cd)	IEC 62321: 2008, section 9/10	ICP-OES	2 mg/kg
Mercury (Hg)	IEC 62321: 2008, section 7	ICP-OES	2 mg/kg
Chromium (Cr)	IEC 62321: 2008, Annex B/C	UV-VIS	2 mg/kg
PBBs/ PBDEs	IEC 62321: 2008, Annex A	GC-MS	5 mg/kg
PFOA	US EPA 3550C : 2007	GC-MS	5 mg/kg
PFOS	US EPA 3540C : 1996	LC-MSD	10 mg/kg
Fluorine/ Chlorine/ Bromine/ Iodine	BS EN 14582 : 2007	IC	/

Conclusion:

-When tested as specified the submitted sample complied with the requirements of commission Decision of 18 Aug 2005 amending Directive 2002/95/EC notified under document 2005/618/EC

*****FOR FURTHER DETAILS, PLEASE REFER TO THE FOLLOWING PAGE(S)*****

Signed for AOV Ltd.

Written by

Inspected by

Approved by

This Test Report is issued by the Company subject to its Conditions of Issuance of Test Report printed overleaf or attached. The results shown in this Test Report refer only to the sample(s) tested unless otherwise stated and such sample(s) are retained for 30days only. This Test Report shall not be reproduced expected in full, without written approval of the Company.

Shenzhen AOV Testing Technology Co., Ltd. Kunshan Branch

Southern China Add: AOV Building, Xueyuan Road East, University City, Shenzhen (Tangliang Village, Xili Town, Nanshan District)
East China Add: No.8 Minguan Road, Xin Town, Kunshan City, Jiangsu
Tel: 86-512-5510 8000 Fax: 86-512-5510 8808
Http: //www.aovt.com



Test Flow:

1. To Determine Lead, Cadmium Content (for Electronics):

Tested by: *Condy*

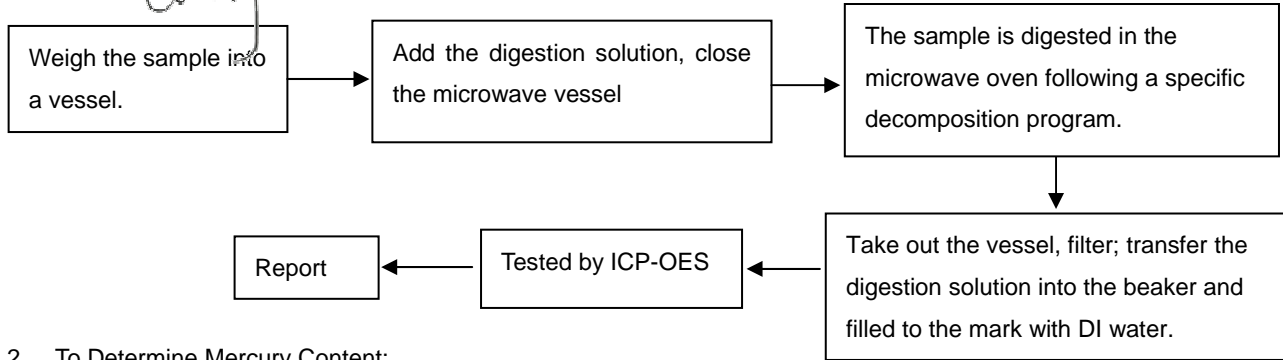

2. To Determine Mercury Content:

Tested by: *Condy*

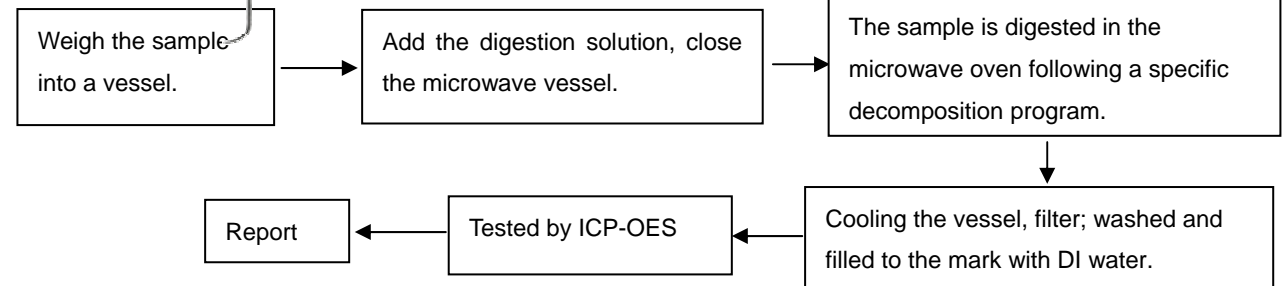

3. To Determine Hexavalent Chromium Content (for Electronics):

Tested by: *Danae*

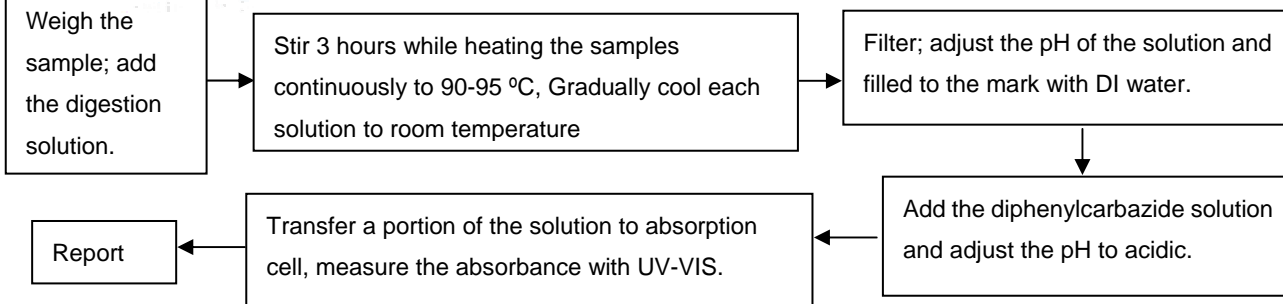

4. To Determine PBBs/PBDEs Content:

Tested by: *Carina*

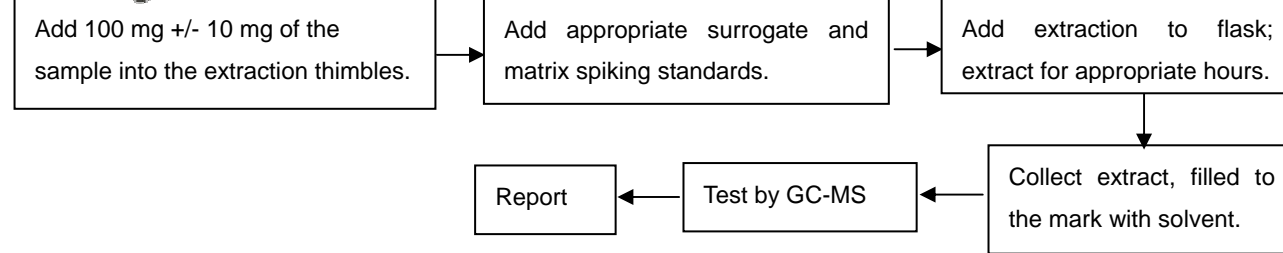

This Test Report is issued by the Company subject to its Conditions of Issuance of Test Report printed overleaf or attached. The results shown in this Test Report refer only to the sample(s) tested unless otherwise stated and such sample(s) are retained for 30days only. This Test Report shall not be reproduced expected in full, without written approval of the Company.



5. To Determine Lead, Cadmium Content (for metal):

Tested by: *Condy*

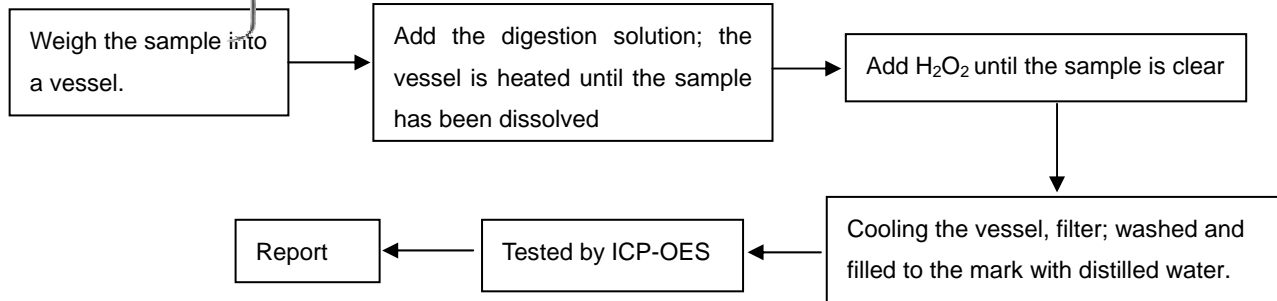

6. To Determine Hexavalent Chromium Content in metals:

Tested by: *Danae*

6.1 spot-test

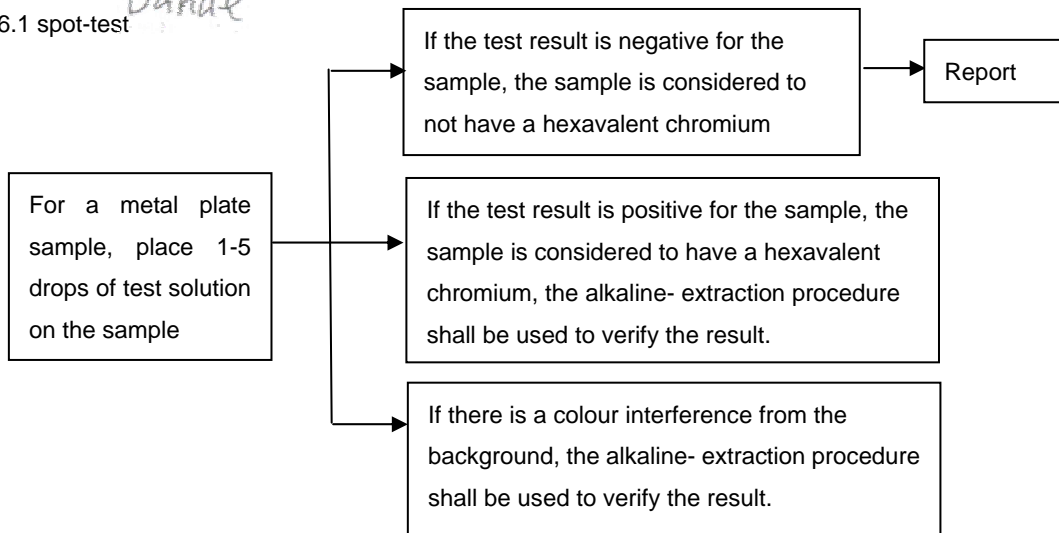

6.2 alkaline- extraction Method

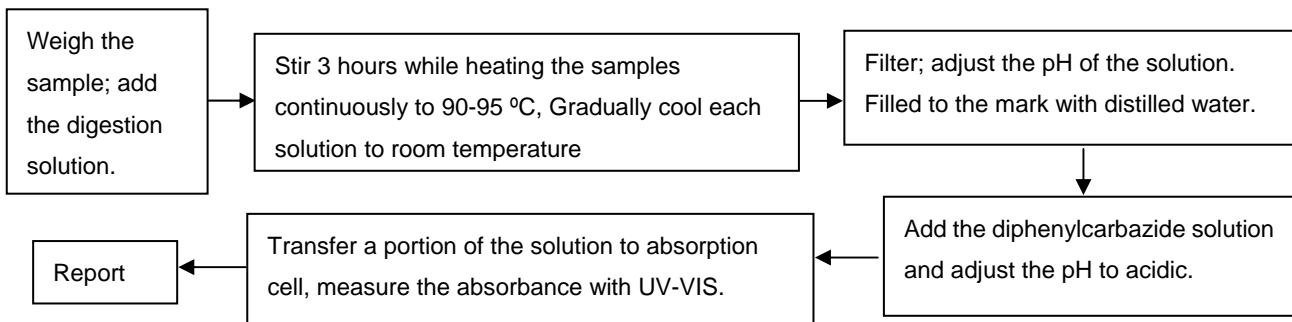

This Test Report is issued by the Company subject to its Conditions of Issuance of Test Report printed overleaf or attached. The results shown in this Test Report refer only to the sample(s) tested unless otherwise stated and such sample(s) are retained for 30days only. This Test Report shall not be reproduced expected in full, without written approval of the Company.



7. To Determine PFOA Content:

Tested by: *Carina*

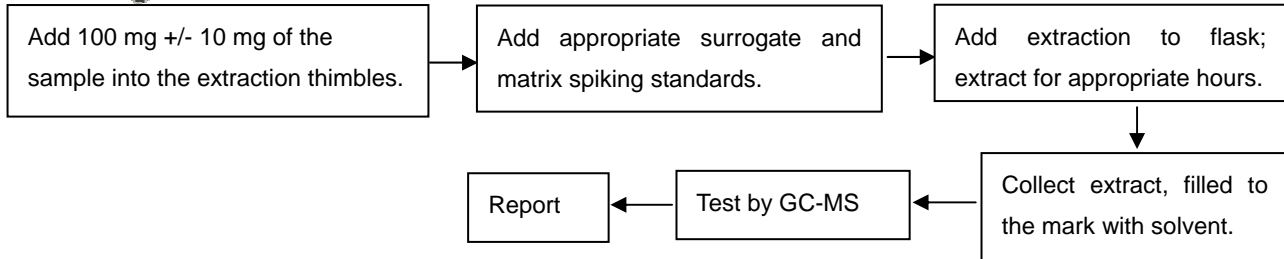

8. To Determine PFOS Content:

Tested by: *Carina*

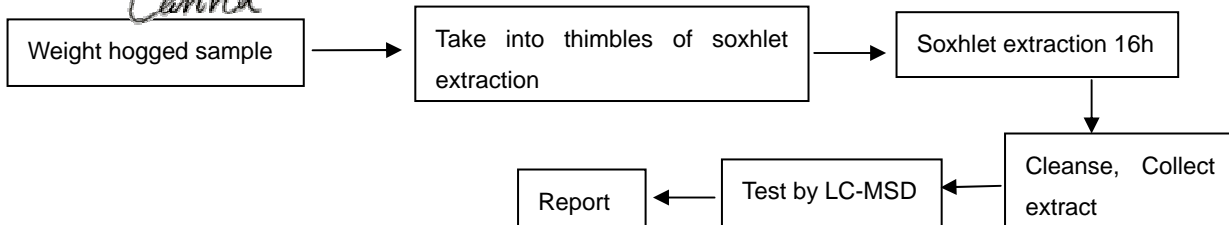

9. To Determine Fluorine, Chlorine, Bromine and Iodine Content:

Tested by: *Jason*

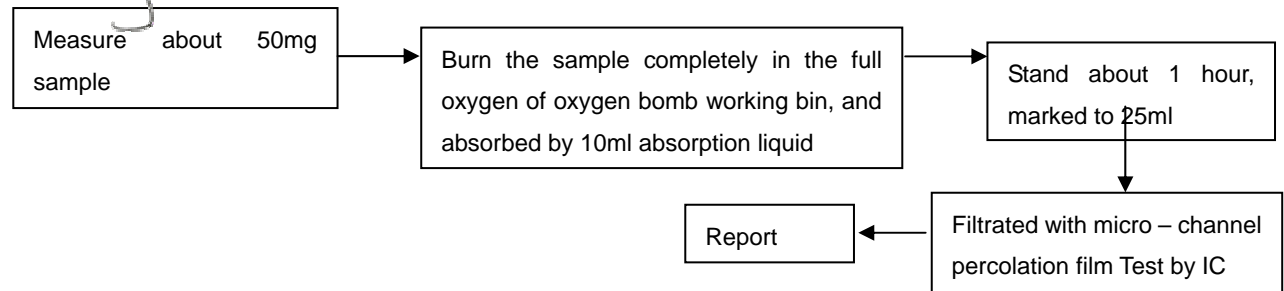

Test Results:

1) ROHS:

Item	Unit	RoHS Limit	A	B
Lead (Pb)	mg/kg	1000	N.D.	N.D.
Cadmium (Cd)	mg/kg	100	2.3	N.D.
Mercury (Hg)	mg/kg	1000	N.D.	N.D.
Chromium(Cr) by spot test	/	/	Negative	/
Chromium (Cr)	mg/kg	1000	N.D.	N.D.

This Test Report is issued by the Company subject to its Conditions of Issuance of Test Report printed overleaf or attached. The results shown in this Test Report refer only to the sample(s) tested unless otherwise stated and such sample(s) are retained for 30days only. This Test Report shall not be reproduced expected in full, without written approval of the Company.



Flame Retardants	Unit	RoHS Limit	B
PBBs	mg/kg	1000	N.D.
MonoBB	mg/kg	/	N.D.
DiBB	mg/kg	/	N.D.
TriBB	mg/kg	/	N.D.
TetraBB	mg/kg	/	N.D.
PentaBB	mg/kg	/	N.D.
HexaBB	mg/kg	/	N.D.
HeptaBB	mg/kg	/	N.D.
OctaBB	mg/kg	/	N.D.
NonaBB	mg/kg	/	N.D.
DecaBB	mg/kg	/	N.D.
PBDEs	mg/kg	1000	N.D.
MonoBDE	mg/kg	/	N.D.
DiBDE	mg/kg	/	N.D.
TriBDE	mg/kg	/	N.D.
TetraBDE	mg/kg	/	N.D.
PentaBDE	mg/kg	/	N.D.
HexaBDE	mg/kg	/	N.D.
HeptaBDE	mg/kg	/	N.D.
OctaBDE	mg/kg	/	N.D.
NonaBDE	mg/kg	/	N.D.
DecaBDE	mg/kg	/	N.D.

2) PFOA content:

Item	Unit	Limit	A	B
PFOA	mg/kg	50	N.D.	N.D.

3) PFOS content:

Item	Unit	Limit	A	B
Perfluorooctane Sulfonates (PFOS) PFOS – Acid PFOS – Metal Salt	mg/kg	See note	N.D.	N.D.

This Test Report is issued by the Company subject to its Conditions of Issuance of Test Report printed overleaf or attached. The results shown in this Test Report refer only to the sample(s) tested unless otherwise stated and such sample(s) are retained for 30days only. This Test Report shall not be reproduced expected in full, without written approval of the Company.



Test Report

NO.: AKS0905152020F

Date: May 21, 2009

Page 6 of 7

Note:

- Reference information: Directive 2006/122/EC
- (i) May not be placed on the market or used as a substance or constituent of preparations in a concentration equal to or higher than 0.005% by mass.
- (ii) May not be placed on the market in semi-finished products or articles, or parts thereof, if the concentration of PFOS is equal to or higher than 0.1% by mass calculated with reference to the mass of structurally or microstructurally distinct parts that contain PFOS or, for textiles or other coated materials, if the amount of PFOS is equal to or higher than $1\mu\text{g}/\text{m}^2$ of the coated material.

4) Fluorine, Chlorine, Bromine and Iodine Content:

Item	Unit	MQL	Limit	B
Fluorine (F)	mg/kg	50	/	N.D.
Chlorine (Cl)	mg/kg	50	900	N.D.
Bromine (Br)	mg/kg	50	900	N.D.
Iodine (I)	mg/kg	50	/	N.D.
Total (Br+ Cl)	mg/kg	/	1500	N.D.

Specimen Description:

A: Metal pin

B: Black plastic body

Note:

- Specimens, which requested to determine Cadmium, Mercury and Lead Content, have been dissolved completely.
- mg/kg=ppm
- N.D.=not detected(<MQL)
- MQL=Method Quantitation Limit
- Spot-test:
Negative=Absence of Cr();
Positive=Presence of Cr();
- Photo is included

This Test Report is issued by the Company subject to its Conditions of Issuance of Test Report printed overleaf or attached. The results shown in this Test Report refer only to the sample(s) tested unless otherwise stated and such sample(s) are retained for 30days only. This Test Report shall not be reproduced expected in full, without written approval of the Company.

Shenzhen AOV Testing Technology Co., Ltd. Kunshan Branch

Southern China Add: AOV Building, Xueyuan Road East, University City, Shenzhen (Tangliang Village, Xili Town, Nanshan District)
East Ching Add: No. 8 Minguan Road, Xin Town, Kunshan City, Jiangsu
Tel: 86-512-5510 8000 Fax: 86-512-5510 8808
Http: //www.aovt.com



Photograph of Sample



SOT23-5

End of Report

This Test Report is issued by the Company subject to its Conditions of Issuance of Test Report printed overleaf or attached. The results shown in this Test Report refer only to the sample(s) tested unless otherwise stated and such sample(s) are retained for 30days only. This Test Report shall not be reproduced expected in full, without written approval of the Company.