

## General Description

The AP3710 is a green-mode PWM controller, its main applications are low power supplies such as offline battery chargers, adapters, STB and other auxiliary supplies, where the needs for low no load power, low total cost and high reliability are all required.

The functional blocks of AP3710 include: under voltage lockout with low start-up current; precise voltage reference for internal comparators; PWM comparator with current limit control, feedback signal and band-gap input; short circuit comparator and open circuit protection for opto-coupler.

The AP3710 operates at a fixed 60kHz switching frequency, its output connects to the emitter of high voltage NPN transistor or the source of MOSFET. In normal mode, it works as a switch to turn on or turn off the external transistor. In failure modes like open loop, over voltage or overload due to short circuit, the chip enters into an auto restart mode controlled by the internal protection unit.

The AP3710 is available in SOIC-8 and DIP-8 packages.

## Features

- Current Mode Control with Skip Cycle Capability
- Low Start-up Current: 0.25 mA
- Low Operating Current: 0.45mA
- Output Current Capacity: 900 mA
- Fixed Switching Frequency: 60 kHz
- Frequency Dithering for Low EMI
- Under-Voltage Lockout with Hysteresis
- Built-in Slope Compensation
- Short Circuit Protection
- Open and Short Circuit Protection for Opto-Coupler
- Maximum Input Power is 0.2W under No Load
- Maximum Input Power is 1W under 0.5W Load
- Low Total Cost Solution

## Applications

- Adapters
- Battery Chargers
- Set Top Boxes
- Auxiliary Supplies
- DVD

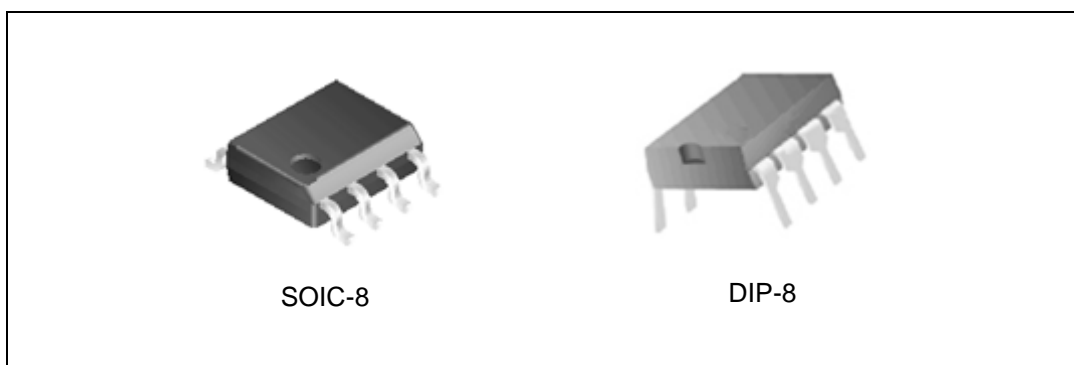

Figure 1. Package Types of AP3710

**LOW POWER PWM CONTROLLER FOR OFF-LINE ADAPTER** **AP3710**

**Pin Configuration**

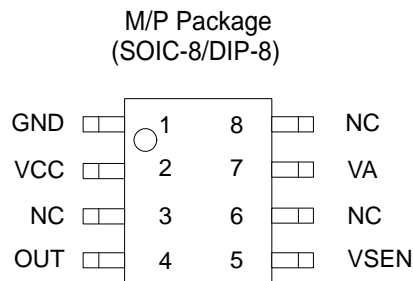

Figure 2. Pin Configuration of AP3710 (Top View)

**Pin Description**

Pin Number	Pin Name	Function
1	GND	Power supply ground
2	VCC	The power supply of the IC and this terminal is also used for the feedback control
3, 6, 8	NC	Not connected
4	OUT	The PWM output is directly connected to the emitter of NPN transistor or the source of MOSFET
5	VSEN	It is used for line voltage compensation, and PWM uses this to terminate the output switch conduction
7	VA	It is used for short circuit protection, and this terminal will be pulled down to low level when short circuit happens at the load side

**LOW POWER PWM CONTROLLER FOR OFF-LINE ADAPTER      AP3710**

**Functional Block Diagram**

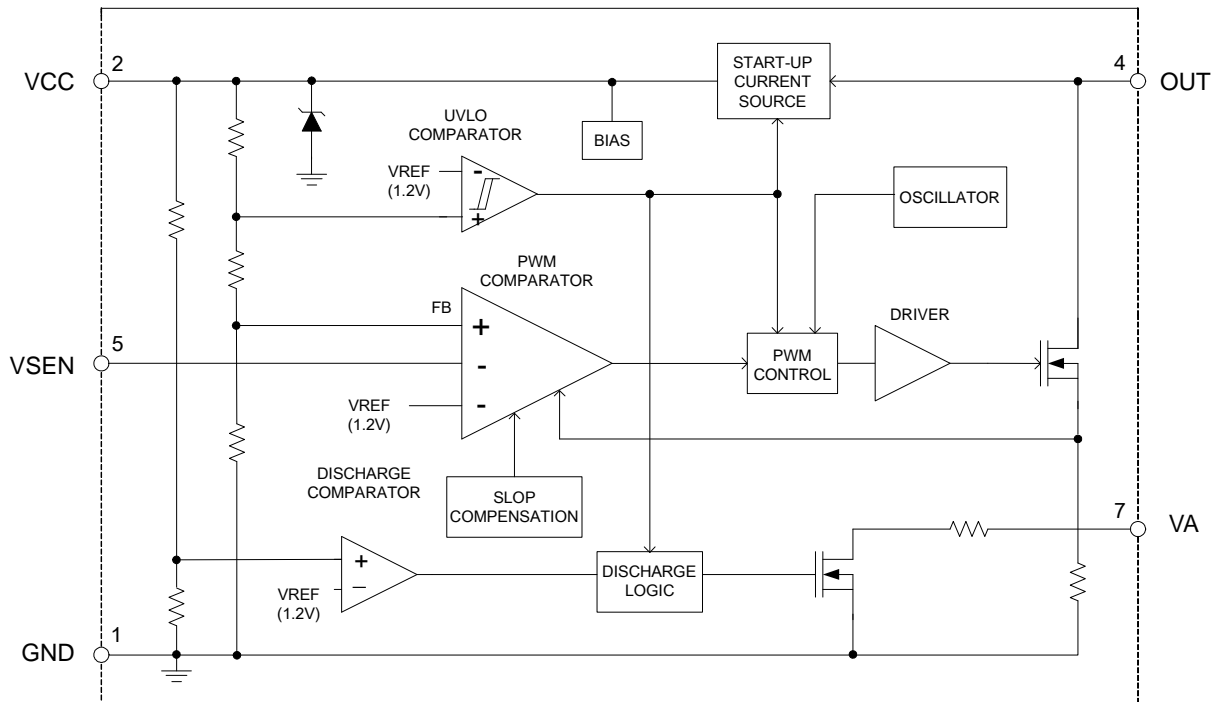
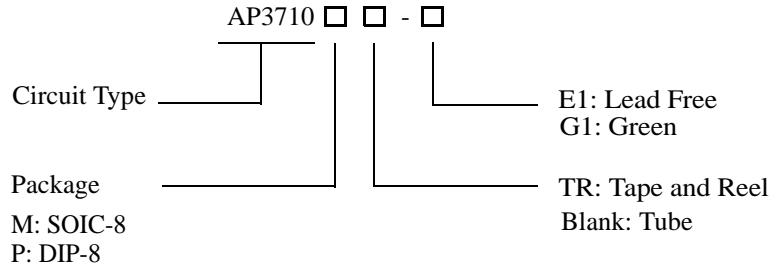

Figure 3. Functional Block Diagram of AP3710



**LOW POWER PWM CONTROLLER FOR OFF-LINE ADAPTER AP3710**

**Ordering Information**



Package	Switching Frequency	Temperature Range	Part Number		Marking ID		Packing Type
			Lead Free	Green	Lead Free	Green	
SOIC-8	60kHz	-40 to 85°C	AP3710M-E1	AP3710M-G1	3710M-E1	3710M-G1	Tube
			AP3710MTR-E1	AP3710MTR-G1	3710M-E1	3710M-G1	Tape & Reel
DIP-8	60kHz	-40 to 85°C	AP3710P-E1	AP3710P-G1	AP3710P-E1	AP3710P-G1	Tube

BCD Semiconductor's Pb-free products, as designated with "E1" suffix in the part number, are RoHS compliant. Products with "G1" suffix are available in green packages.

**Absolute Maximum Ratings (Note 1)**

Parameter	Value	Unit
Supply Voltage	-0.3 to 6.3	V
Voltage at OUT	-0.3 to 40	V
Analog Input at V <sub>SEN</sub>	-0.3 to 6.3	V
Output Current at OUT	Internally limited	A
Power Dissipation	0.6	W
Operating Junction Temperature	150	°C
Storage Temperature	-65 to 150	°C
Lead Temperature (Soldering, 10s)	300	°C
ESD (Machine Model)	250	V
ESD (Human Body Model)	3000	V

Note 1: Stresses greater than those listed under "Absolute Maximum Ratings" may cause permanent damage to the device. These are stress ratings only, and functional operation of the device at these or any other conditions beyond those indicated under "Recommended Operating Conditions" is not implied. Exposure to "Absolute Maximum Ratings" for extended periods may affect device reliability.



**LOW POWER PWM CONTROLLER FOR OFF-LINE ADAPTER** **AP3710**

**Electrical Characteristics**

( $V_{CC}=4V$ ,  $T_J=25^{\circ}C$ , unless otherwise specified.)

Parameter	Symbol	Conditions	Min	Typ	Max	Unit
<b>UVLO SECTION</b>						
Turn on Threshold Voltage	$V_{CC(on)}$		5.30	5.60	5.90	V
Turn off Threshold Voltage	$V_{CC(off)}$		3.4	3.65	3.90	V
Discharge Voltage	$V_{DIS}$		2.7	2.9	3.1	V
<b>STANDBY CURRENT SECTION</b>						
Start-up Current	$I_{ST}$	$V_{CC}=4V$		0.25	0.4	mA
Operating Current	$I_{CC(opr)}$			0.45	0.7	
$V_{CC}$ Zener Voltage	$V_Z$	$I_{CC}=10mA$	6.5	7	7.5	V
Dynamic Impedance	$R_{VCC}$	$V_{CC}=3.8$ to $4.8V$ (Note 2)	10	18	30	k $\Omega$
<b>INTERNAL OSCILLATOR</b>						
Switching Frequency	$F_{SW}$	(Note 3)	50	60	70	kHz
Frequency Dithering			$\pm 2$	$\pm 3.5$	$\pm 5$	kHz
Temperature Stability		$-40$ to $85^{\circ}C$		5		%
<b>DRIVE OUTPUT SECTION</b>						
OUT Turn-on Voltage	$V_{OUT(on)}$		7.6	9.3	11	V
OUT Turn-off Voltage	$V_{OUT(off)}$		5.7	6.8	7.9	V
Rise Time	$T_R$	$C_L=1nF$ , $15\Omega$ pull-up		60		ns
Fall Time	$T_F$	$C_L=1nF$ , $15\Omega$ pull-up		30		
Maximum Duty Cycle	$D_{MAX}$	$V_{CC(off)} + 0.2V$	68	75	82	%
Minimum Duty Cycle		$V_{CC}=V_{CC(on)}-0.2V$		3	5	
Driver OUT On-Resistance	$R_{OUT}$	$I_{OUT}=0.7A$		3	5	$\Omega$
Switch Off Current (OUT)		Driver off, $V_{OUT}=10V$		20	40	$\mu A$
Effective Current Limit	$I_{LIM}$	$V_{CC}=V_{CC(off)}+0.5V$	800	900		mA
OUT Current Coefficient	$G_A$			-0.6		A/V
<b>CURRENT SECTION</b>						
Maximum Input Signal	$V_{SEN}$		0.9	1.0	1.1	V

Note 2: Guaranteed by design, not tested in production.

Note 3: The fixed oscillation frequency, the frequency jittering is not included.

**LOW POWER PWM CONTROLLER FOR OFF-LINE ADAPTER      AP3710**

**Electrical Characteristics (Continued)**

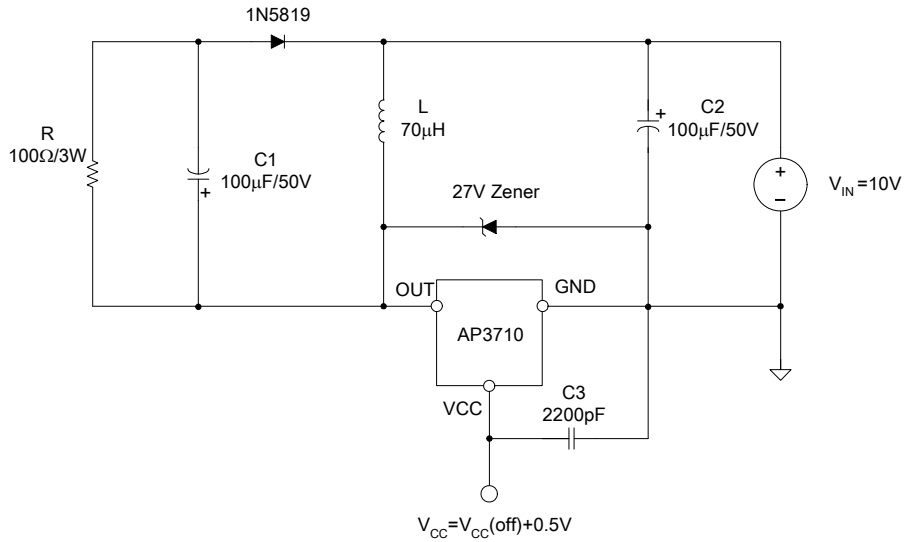

Figure 4. The Test Circuit for Current Limit



**LOW POWER PWM CONTROLLER FOR OFF-LINE ADAPTER** **AP3710**

**Typical Performance Characteristics**

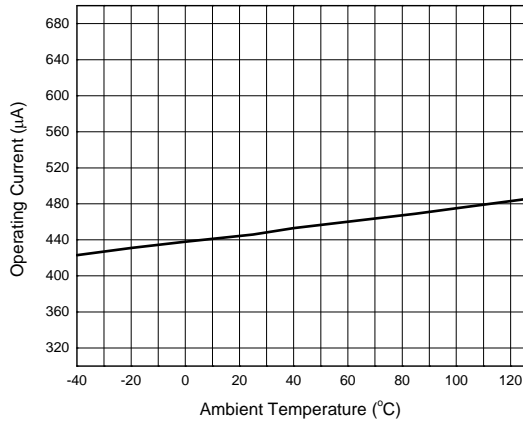

Figure 5. Operating Current vs. Ambient Temperature

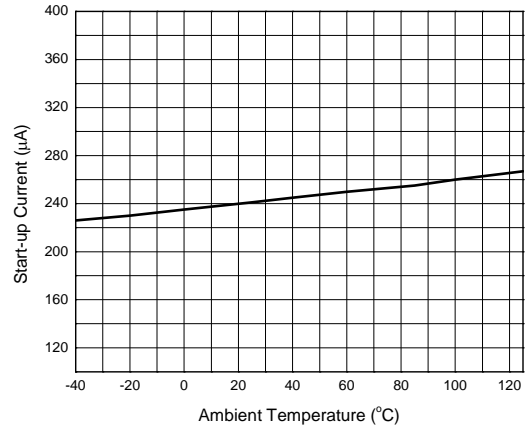

Figure 6. Start-up Current vs. Ambient Temperature

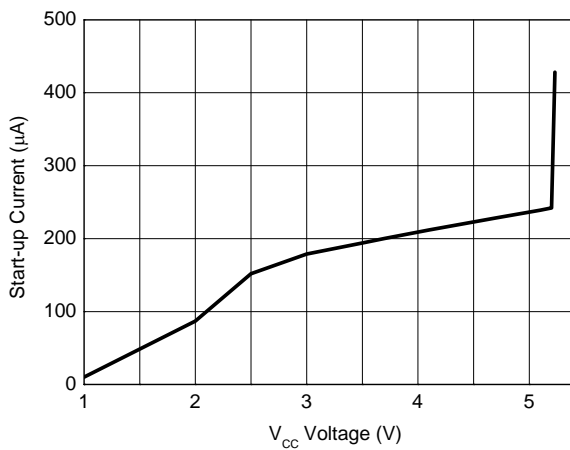

Figure 7. Start-up Current vs. V<sub>CC</sub> Voltage

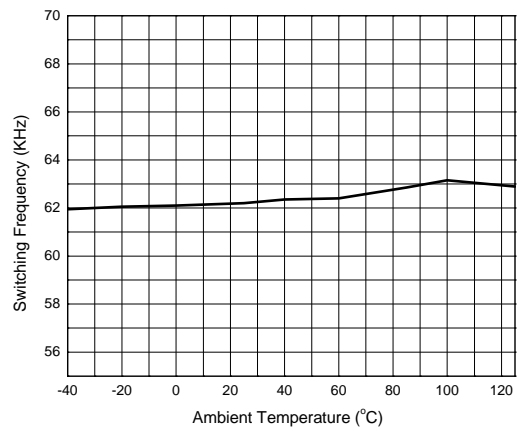

Figure 8. Switching Frequency vs. Ambient Temperature



**LOW POWER PWM CONTROLLER FOR OFF-LINE ADAPTER** **AP3710**

**Typical Performance Characteristics (Continued)**

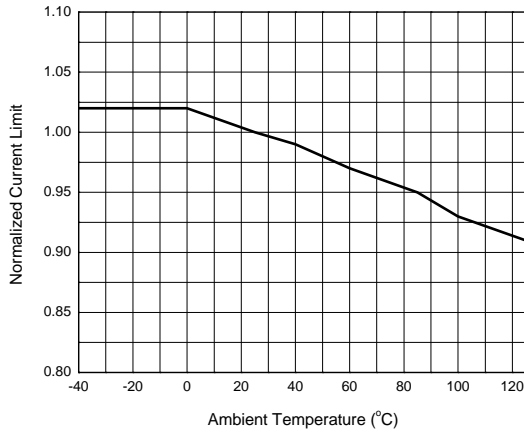

Figure 9. Normalized Current Limit vs. Ambient Temperature

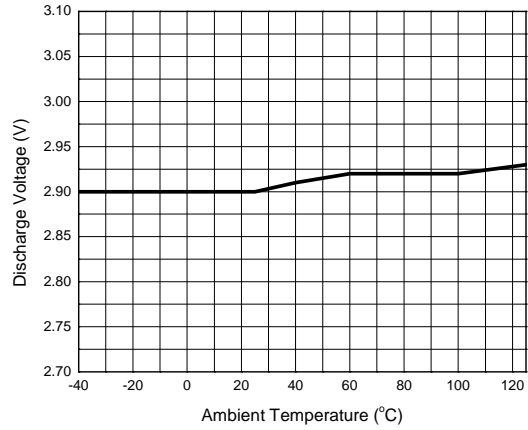

Figure 10. Discharge Voltage vs. Ambient Temperature

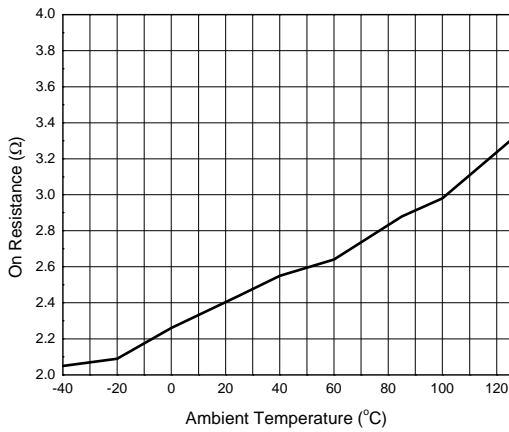

Figure 11. On Resistance vs. Ambient Temperature

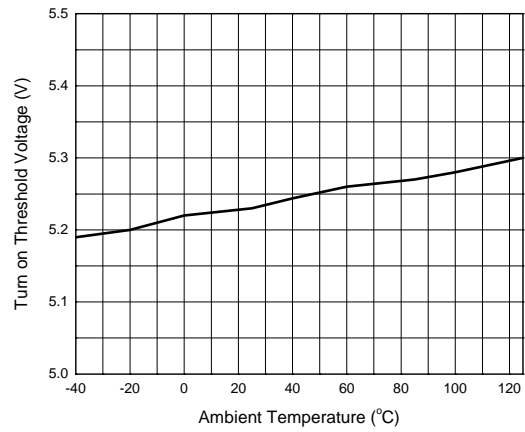

Figure 12. Turn on Voltage vs. Ambient Temperature

**LOW POWER PWM CONTROLLER FOR OFF-LINE ADAPTER AP3710**

**Function Description**

**1. UVLO and Start up Circuit**

The AP3710's turn on threshold voltage is 5.6V and its turn off threshold voltage is 3.65V, so the UVLO hysteresis voltage is 1.95V, which helps AP3710 to draw adequate energy to supply VCC terminal during start-up. Please see Figure 13 for UVLO chart.

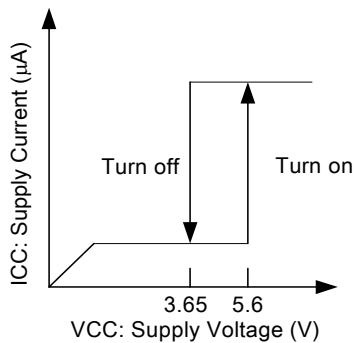

Figure 13. 5.6/3.65V UVLO Threshold of AP3710

The VCC terminal in Figure 3 is used for both bias supply and feedback control. When AP3710 is powered on, the start-up current source turns on and it can not turn off until VCC level increases to its threshold value and PWM pulse is produced.

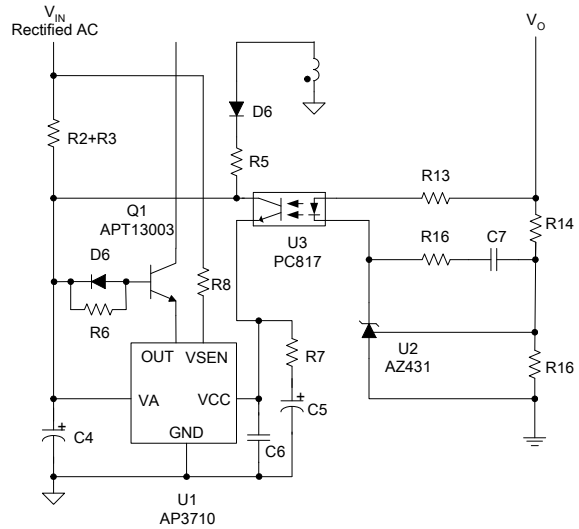

Figure 14. The Start-up Circuit of Typical Application

In start-up section of typical application shown by Figure 14, the rectified line voltage V<sub>IN</sub> charges the capacitor C4 through start-up resistor R2+R3 until Q1 is turned on so OUT terminal can directly drive external Q1, a MOSFET inside AP3710 is connected in series with the Q1.

Once the start-up is set up, the auxiliary bias winding will supply the VCC terminal enough operating current. The start-up sequence is shown in Figure 15.

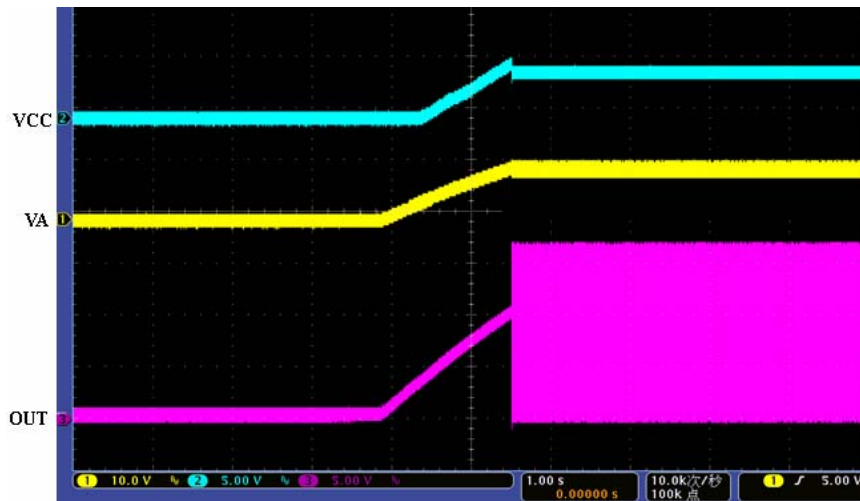

Figure 15. Power up Waveforms

**LOW POWER PWM CONTROLLER FOR OFF-LINE ADAPTER** **AP3710**

**Function Description (Continued)**

**2. VCC/Feedback Control**

In Figure 14, an opto-coupler and secondary constant voltage consists of voltage feedback network. Voltage feedback loop consists of shunt regulator AZ431 and FB/VCC terminal of AP3710. When load is heavy, the voltage on VCC terminal will decrease to enlarge duty cycle; on the contrary, if load drops, the voltage on VCC will increase to reduce duty cycle.

**3. Skip Cycle Mode Operation**

The AP3710 enters skip cycle mode when load power drops below a given level, and this is performed by sensing the VCC voltage level, i.e., the heavier load power, the lower VCC voltage level. In normal operation, the VCC terminal indicates a peak inductance current under certain load power. If the load power decreases, VCC voltage level increases to ask for less peak current. When it reaches a determined value, the IC prevents the current from decreasing further down and starts to blank the output pulses, the IC then enters the skip cycle mode operation. Figure 16 is the sketch for the two operation mode.

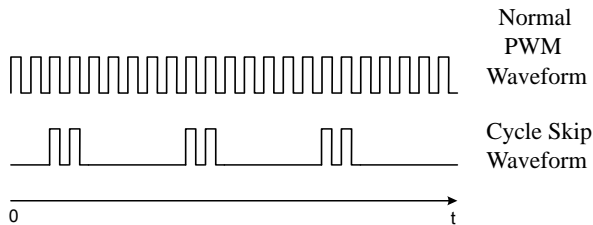

Figure 16. Skip Cycle and Normal PWM Waveform

**4. Slope Compensation**

The AP3710 is current mode PWM controller, and it regulates peak inductance current by its current control loop. It is known that a continuous conduction mode SMPS may induce noise and harmonic oscillation on current sense or feedback signal, and this is especially serious when duty cycle exceeds 50%. The internal slope compensation of AP3710 can improve power supply stability by increasing the current slope.

**5. Current Limit Control**

The AP3710 employs current mode control to improve transient response and voltage stability. In Figure 3, the external inductor current through the OUT pin is converted to a voltage by an internal resistor, and this voltage will participate to control duty cycle and peak inductor current.

**6. Frequency Dithering**

Frequency dithering is performed by periodically spreading a single switching frequency into adjacent frequency band, so the peak energy is spread. This technique can improve EMI performance by reducing both quasi peak and average EMI emissions.

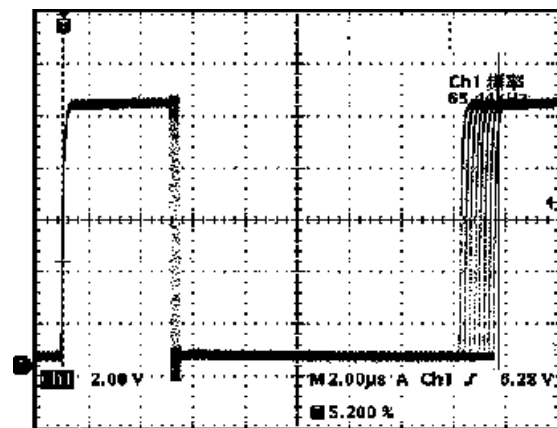

Figure 17. Frequency Dither Influences the Switching Cycle

**LOW POWER PWM CONTROLLER FOR OFF-LINE ADAPTER** **AP3710**

**Function Description (Continued)**

**7. Short Circuit Protection**

Internal short circuit control can protect a SMPS from being damaged when short circuit at its output happens.

In Figure 18, when VCC drops below its turn off threshold value, the UVLO comparator's output will control the Discharge Logic to pull VA terminal to low level, and the low level is kept before the VCC voltage drops below the threshold value of discharge comparator. Then the system will re-startup from C4 charging again and the same process will repeat indefinitely. The long start-up period makes the input power low enough to ensure the whole system in safety under output short circuit condition.

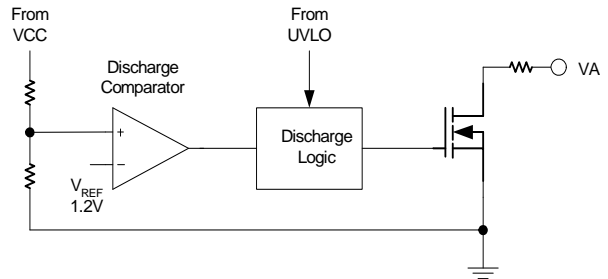

Figure 18. Short Circuit Protection Block



**LOW POWER PWM CONTROLLER FOR OFF-LINE ADAPTER****AP3710****Bill of Materials for Figure 19**

Designator	Part Type	Designator	Part Type
R1	Resistor, NTC Resistor, 5Ω	C1, C2	Electrolytic Capacitor, 10 μF/400V, φ10
R2, R3	Resistor, 1MΩ, 1206	C3	Capacitor, 2200pF, d=5mm
R4	Resistor, 68kΩ, 1206	C4, C5	Capacitor, 10μF, d=4.5mm
R5	Resistor, 3Ω, 0805	C6	Capacitor, 22nF, 0805
R6	Resistor, 200Ω, 0805	C7	Capacitor, 0.47μF, 0805
R7	Resistor, 2kΩ, 0805	C8	Electrolytic Capacitor, 1000μF
R8	Resistor, 5.1MΩ, SIP	C9	Electrolytic Capacitor, 220μF
R9, R15, R16	Resistor, 3kΩ, 0805	C10	Y Capacitor, 2200pF
R11	Resistor, 15 Ω, 1206	C11	Capacitor, 1nF, 0805
R13	Resistor, 1kΩ, 0805	L2	Inductor, 300μH/0.3A
R14	Resistor, 11.4kΩ, 0805	L4	Inductor, 100μH/1A
		T1	Transformer, EE-20
D1 to D4	Diode, 1N4007, DO-41	ZD2	Zener, 13V/1W
D5, D6	Diode, 1N4148, LL-34	Q1	Transistor, APT13003E, TO-126
D7	Diode, FR107, DO-15	U1	IC, AP3710
D8	Diode, 3100, DO-201	U3	Opto-coupler, PC817, DIP-4



**LOW POWER PWM CONTROLLER FOR OFF-LINE ADAPTER** **AP3710**

**Mechanical Dimensions**

**SOIC-8**

**Unit: mm(inch)**

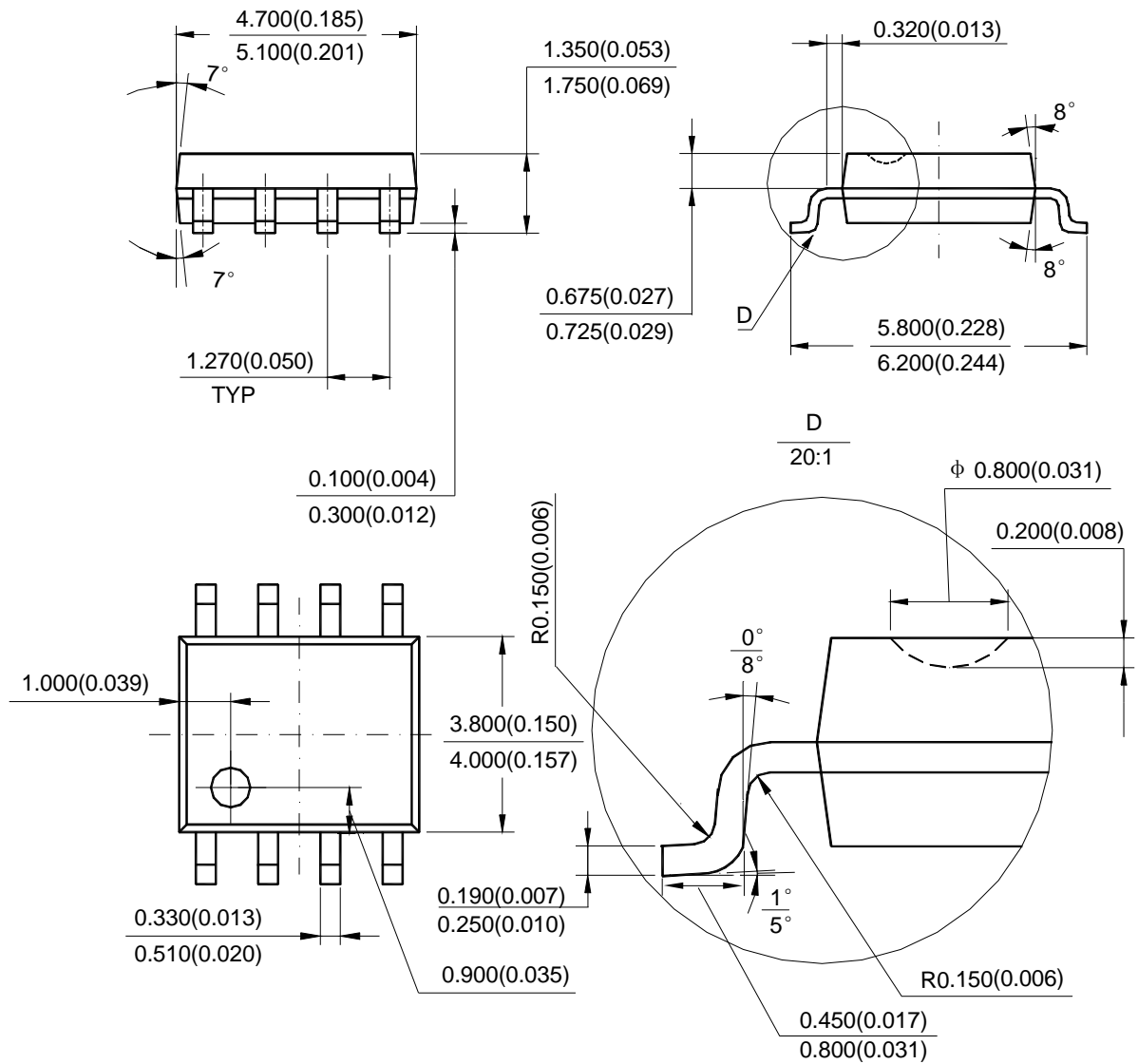



**LOW POWER PWM CONTROLLER FOR OFF-LINE ADAPTER** **AP3710**

**Mechanical Dimensions (Continued)**

**DIP-8**

**Unit: mm(inch)**

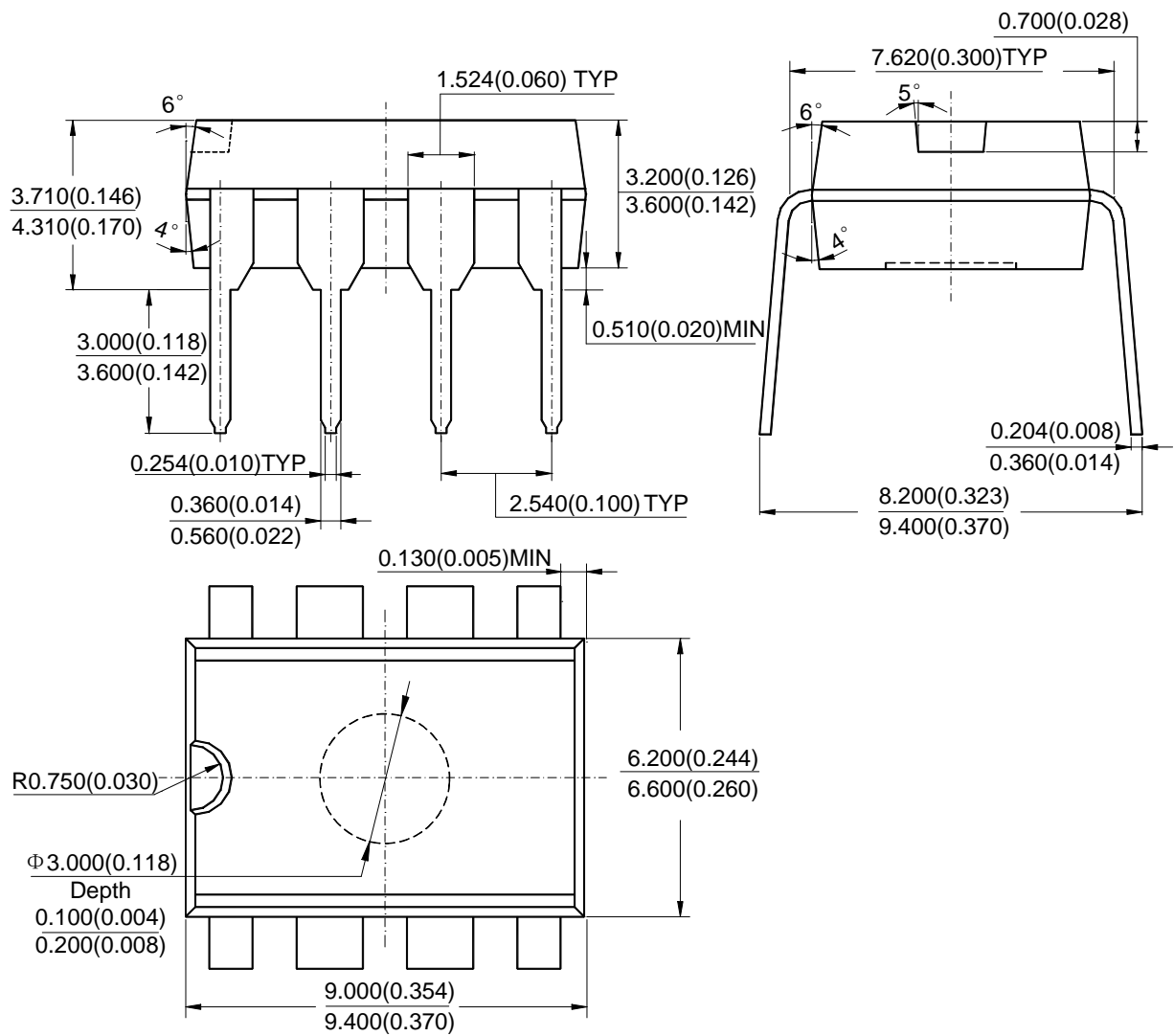



## **BCD Semiconductor Manufacturing Limited**

<http://www.bcdsemi.com>

### **IMPORTANT NOTICE**

BCD Semiconductor Manufacturing Limited reserves the right to make changes without further notice to any products or specifications herein. BCD Semiconductor Manufacturing Limited does not assume any responsibility for use of any its products for any particular purpose, nor does BCD Semiconductor Manufacturing Limited assume any liability arising out of the application or use of any its products or circuits. BCD Semiconductor Manufacturing Limited does not convey any license under its patent rights or other rights nor the rights of others.

---

#### **MAIN SITE**

##### **- Headquarters**

##### **BCD Semiconductor Manufacturing Limited**

No. 1600, Zi Xing Road, Shanghai ZiZhu Science-based Industrial Park, 200241, China  
Tel: +86-21-24162266, Fax: +86-21-24162277

##### **- Wafer Fab**

##### **Shanghai SIM-BCD Semiconductor Manufacturing Co., Ltd.**

800 Yi Shan Road, Shanghai 200233, China  
Tel: +86-21-6485 1491, Fax: +86-21-5450 0008

#### **REGIONAL SALES OFFICE**

##### **Shenzhen Office**

##### **Shanghai SIM-BCD Semiconductor Manufacturing Co., Ltd., Shenzhen Office**

Unit A Room 1203, Skyworth Bldg., Gaoxin Ave. 1.S., Nanshan District, Shenzhen, China  
Tel: +86-755-8826 7951  
Fax: +86-755-8826 7865

##### **Taiwan Office**

##### **BCD Semiconductor (Taiwan) Company Limited**

4F, 298-1, Rui Guang Road, Nei-Hu District, Taipei, Taiwan  
Tel: +886-2-2656 2808  
Fax: +886-2-2656 2806

##### **USA Office**

##### **BCD Semiconductor Corp.**

30920 Huntwood Ave. Hayward, CA 94544, USA  
Tel : +1-510-324-2988  
Fax: +1-510-324-2788