

CURRENT MODE PWM CONTROLLER

AP384XC

General Description

The AP3842C/3C/4C/5C are high performance fixed frequency current-mode PWM controller series.

These integrated circuits are optimized for off-line and DC-DC converter applications with minimum external components. They feature under-voltage lockout (UVLO) circuit with low start-up current, trimmed oscillator for precise duty cycle control, current sense comparator providing maximum current limiting and a totem pole output stage for increasing output current. In addition, these ICs also feature accurate protection against over-temperature, over-current and maximal output power.

The AP3842C and AP3844C have UVLO thresholds of 16V(on) and 10V(off); The corresponding thresholds for AP3843C and AP3845C are 8.4 V(on) and 7.6V(off).

The AP3842C and AP3843C can operate approaching 100% duty cycle; AP3844C and AP3845C can operate from zero to 50% duty cycle.

These ICs are available in SOIC-8 and DIP-8 packages.

Features

- Low Start-up Current: 50 μ A
- Robust V_{REF} Line/Load Regulation
Low Line Regulation : 4mV
Low Load Regulation : 4mV
- High Stability of Reference Voltage over a Full Temperature Range: 0.2mV/ $^{\circ}$ C
- Operating Frequency up to 500KHz
- High PWM Frequency Stability over a Full Temperature Range: 2.5%
- High PWM Frequency Stability under a Full Supply Voltage Range: 0.2%
- Accurate Over-temperature Protection with Hysteresis
- UVLO with Hysteresis

Applications

- Off-line Converter
- DC-DC Converter
- Voltage Adapter
- CRT Monitor Power Supply
- Desktop Power Supply
- DVD/STB Power Supply

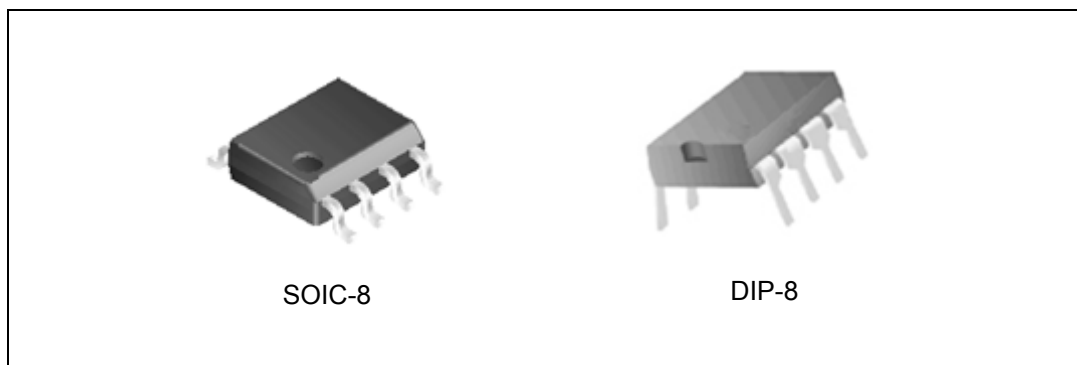

Figure 1. Package Types of AP3842C/3C/4C/5C

CURRENT MODE PWM CONTROLLER

AP384XC

Pin Configuration

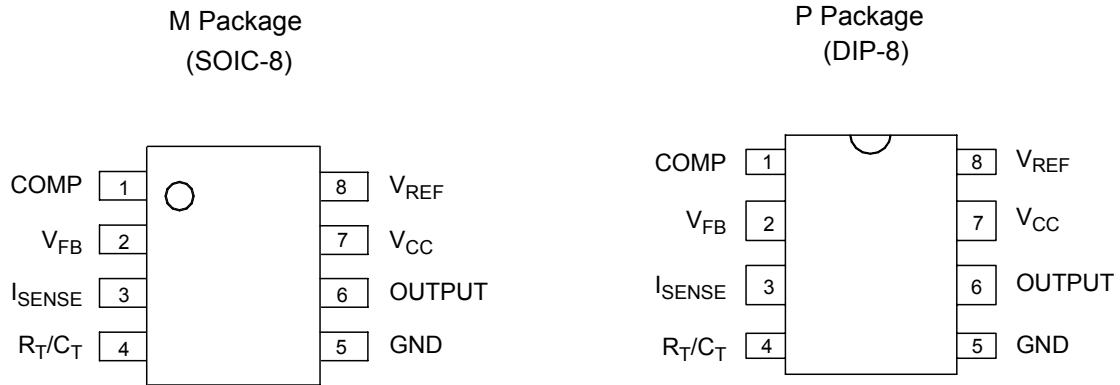

Figure 2. Pin Configuration of AP3842C/3C/4C/5C (Top View)

Pin Description

Pin Number	Pin Name	Function
1	COMP	This pin is the Error Amplifier output and is made available for loop compensation.
2	V_{FB}	The inverting input of the Error Amplifier. It is normally connected to the switching power supply output through a resistor divider.
3	I_{SENSE}	A voltage proportional to inductor current is connected to this input. The PWM uses this information to terminate the output switch conduction.
4	R_T/C_T	The Oscillator frequency and maximum output duty cycle are programmed by connecting resistor R_T to V_{REF} and capacitor C_T to ground. Operation to 500 kHz is possible.
5	GND	The combined control circuitry and power ground.
6	OUTPUT	This output directly drives the gate of a power MOSFET. Peak currents up to 1.0 A are sourced and sunk by this pin.
7	V_{CC}	The positive supply of the control IC.
8	V_{REF}	This is the reference output. It provides charging current for capacitor C_T through resistor R_T .



CURRENT MODE PWM CONTROLLER

AP384XC

Ordering Information

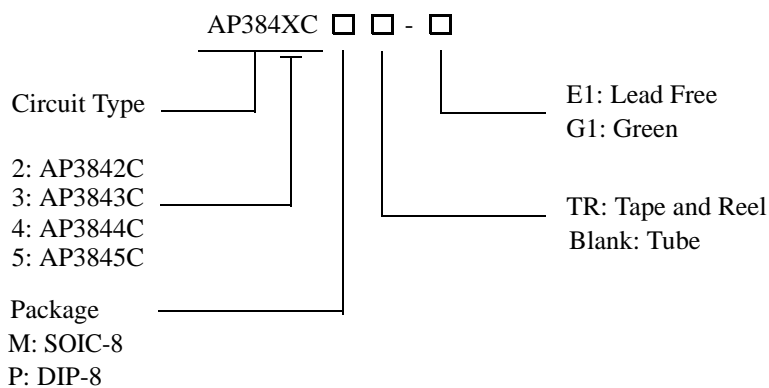

Package	Temperature Range	Part Number		Marking ID		Packing Type
		Lead Free	Green	Lead Free	Green	
SOIC-8	-40 to 85°C	AP3842/3/4/5CM-E1	AP3842/3/4/5CM-G1	3842/3/4/5CM-E1	3842/3/4/5CM-G1	Tube
		AP3842/3/4/5CMTR-E1	AP3842/3/4/5CMTR-G1	3842/3/4/5CM-E1	3842/3/4/5CM-G1	Tape & Reel
DIP-8		AP3842/3/4/5CP-E1	AP3842/3/4/5CP-G1	AP3842/3/4/5CP-E1	AP3842/3/4/5CP-G1	Tube

BCD Semiconductor's Pb-free products, as designated with "E1" suffix in the part number, are RoHS compliant. Products with "G1" suffix are available in green packages.

**CURRENT MODE PWM CONTROLLER****AP384XC****Absolute Maximum Ratings (Note 1, 2)**

Parameter		Symbol	Value	Unit
Supply Voltage		V_{CC}	30	V
Output Current		I_O	± 1	A
Analog Inputs		$V(ANA)$	-0.3 to 6.3	V
Error Amp Output Sink Current		$I_{SINK(E.A)}$	10	mA
Power Dissipation at $T_A < 25\text{ }^\circ\text{C}$ (DIP-8)		P_D (Note 3)	1000	mW
Power Dissipation at $T_A < 25\text{ }^\circ\text{C}$ (SOIC-8)		P_D (Note 3)	460	mW
Junction Operating Temperature		T_J	-40 to 150	$^\circ\text{C}$
Thermal Resistance (Junction to Ambient)	DIP-8	$R_{\theta JA}$	140	$^\circ\text{C/W}$
	SOIC-8		160	$^\circ\text{C/W}$
Storage Temperature Range		T_{STG}	-65 to 150	$^\circ\text{C}$
Lead Temperature (Soldering, 10sec)		T_{LEAD}	+300	$^\circ\text{C}$
ESD (Machine Mode)			250	V

Note 1: Stresses greater than those listed under "Absolute Maximum Ratings" may cause permanent damage to the device. These are stress ratings only, and functional operation of the device at these or any other conditions beyond those indicated under "Recommended Operating Conditions" is not implied. Exposure to "Absolute Maximum Ratings" for extended periods may affect device reliability.

Note 2: All voltages are with respect to pin 5 and all currents are positive into specified terminal.

Note 3: Board thickness 1.6mm, board dimension 90mm X 90mm.

Recommended Operating Conditions

Parameter	Symbol	Min	Max	Unit
Oscillation Frequency	f		500	KHz
Ambient Temperature	T_A	-40	85	$^\circ\text{C}$



CURRENT MODE PWM CONTROLLER

AP384XC

Electrical Characteristics

($V_{CC}=15V$, $R_T=10k\Omega$, $C_T=3.3nF$, $T_A= -40$ to $85^\circ C$, unless otherwise specified.)

Parameter	Symbol	Conditions	Min	Typ	Max	Unit
REFERENCE SECTION						
Reference Output Voltage	V_{REF}	$T_J=25^\circ C$, $I_{REF}=1mA$	4.90	5.00	5.10	V
Total Output Variation		Line, Load, Temp.	4.82		5.18	V
Line Regulation	ΔV_{REF}	$12V \leq V_{CC} \leq 25V$		4	15	mV
Load Regulation	ΔV_{REF}	$1mA \leq I_{REF} \leq 20mA$		4	15	mV
Short Circuit Output Current	I_{SC}	$T_A=25^\circ C$		-100	-180	mA
Temperature Stability				0.2	0.4	mV/ $^\circ C$
OSCILLATOR SECTION						
Oscillation Frequency	f	$T_J=25^\circ C$	47	52	57	KHz
Oscillator Amplitude	V_{OSC}	Pin 4, peak to peak (Note 6)		1.7		V
Temperature Stability		(Note 6)		2.5		%
Voltage Stability		$12V \leq V_{CC} \leq 25V$		0.2	1	%
Discharge Current		$V_{pin 4} = 2V$ (Note 7)	8.5	9.5	10.5	mA
ERROR AMPLIFIER SECTION						
Input Voltage	V_I	$V_{pin 1}=2.5V$	2.45	2.50	2.55	V
Output Sink Current	I_{SINK}	$V_{pin 1}=1.1V$	5	8		mA
Output Source Current	I_{SOURCE}	$V_{pin 1}=5V$	-0.5	-0.8		mA
High Output Voltage	V_{OH}	$R_L=15k\Omega$ to GND	5	7		V
Low Output Voltage	V_{OL}	$R_L=15k\Omega$ to pin 8		0.7	1.1	V
Voltage Gain		$2V \leq V_O \leq 4V$	65	90		dB
Power Supply Rejection Ratio	PSRR	$12V \leq V_{CC} \leq 25V$	60	70		dB
CURRENT SENSE SECTION						
Maximum Input Signal	$V_I(MAX)$	$V_{pin 1}=5V$ (Note 4)	0.9	1	1.1	V
Gain	GV	(Note 4, 5)	2.85	3	3.15	V/V
Power Supply Rejection Ratio	PSRR	$12V \leq V_{CC} \leq 25V$ (Note 4, 6)		70		dB
Delay to Output		$V_{pin 3} = 0$ to $2V$ (Note 6)		150	300	ns
Input Bias Current	I_{BIAS}			-3	-10	μA
OUTPUT SECTION						
Low Output Voltage	V_{OL}	$I_{SINK} = 20mA$		0.1	0.4	V
		$I_{SINK} = 200mA$		1.4	2.2	V
High Output Voltage	V_{OH}	$I_{SOURCE} = 20mA$	13	14		V
		$I_{SOURCE} = 200mA$	12	13		V
Rise Time	t_R	$T_J=25^\circ C$, $C_L=1nF$ (Note 6)		50	150	ns
Fall Time	t_F	$T_J=25^\circ C$, $C_L=1nF$ (Note 6)		50	150	ns

CURRENT MODE PWM CONTROLLER

AP384XC

Electrical Characteristics (Continued)

Parameter	Symbol	Conditions	Min	Typ	Max	Unit
UNDER -VOLTAGE LOCKOUT SECTION						
Start Threshold	V _{TH(ST)}	AP3842C/AP3844C	15	16	17	V
		AP3843C/AP3845C	7.8	8.4	9.0	V
Min. Operation Voltage (After Turn On)	V _{OPR} (Min.)	AP3842C/AP3844C	8.5	10.0	11.5	V
		AP3843C/AP3845C	7.0	7.6	8.2	V
PWM SECTION						
Max. Duty Cycle	D(Max.)	AP3842C/AP3843C	95	97	100	%
	D(Max.)	AP3844C/AP3845C	46	48	50	%
Min. Duty Cycle	D(Min.)				0	%
TOTAL STANDBY CURRENT SECTION						
Start-Up Current	I _{ST}			50	80	μA
Operating Supply Current	I _{CC(OPR)}	V _{pin3} =V _{pin2} =0V		8	12	mA
Zener Voltage	V _Z	I _{CC} =25mA	30	34		V
OVER-TEMPERATURE PROTECT SECTION						
Shutdown Temperature	T _{SHUT}	(Note 6)		155		°C
Temperature Hysteresis	T _{HYS}	(Note 6)		25		°C

Note 4: Parameters are tested at trip point of latch with V_{pin2} = 0.

Note 5: Here gain is defined as:

$$A = \frac{\Delta V_{Pin 1}}{\Delta V_{Pin 3}}, 0 \leq V_{pin3} \leq 0.8V$$

Note 6: These parameters, although guaranteed, are not 100% tested in production.

Note 7: This parameter is measured with R_T=10kΩ to V_{REF}, it contributes 0.3mA of current to the measured value.

So the total current flowing into the CT pin will be 0.3mA higher than the measured value approximately.

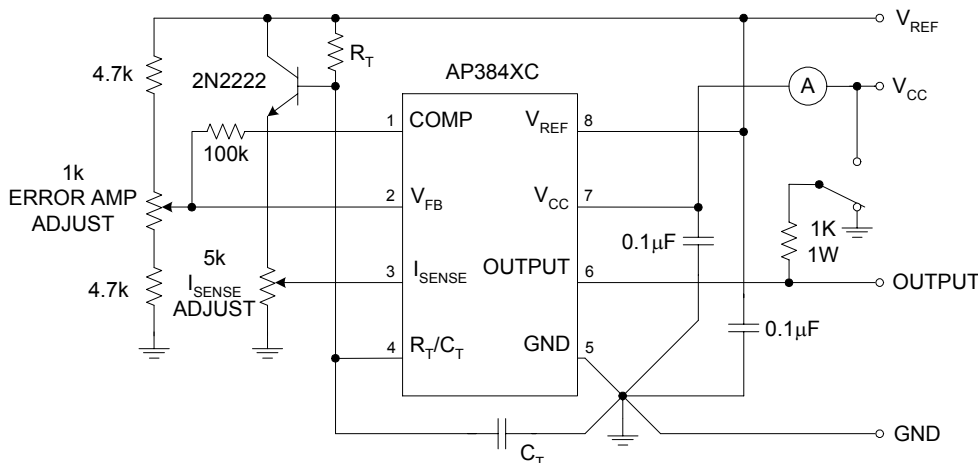

Figure 4. Basic Test Circuit



CURRENT MODE PWM CONTROLLER

AP384XC

Electrical Characteristics (Continued)

Figure 4 is the basic test circuit for AP384XC. In testing, the high peak currents associated with capacitive loads necessitate careful grounding techniques. Timing and bypass capacitors should be connected close to pin 5 in a single point ground. The transistor and 5k potentiometer are used to sample the oscillator waveform and apply an adjustable ramp to pin 3.

Typical Performance Characteristics

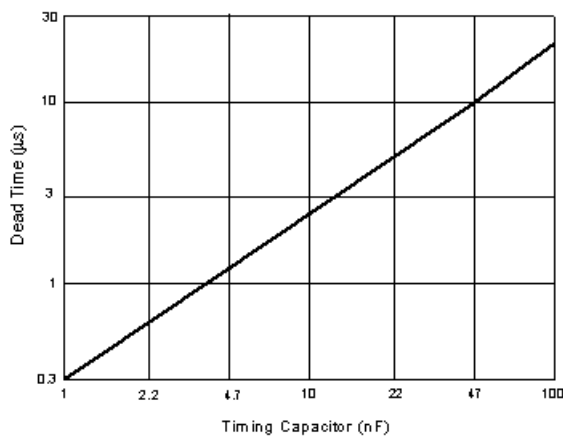

Figure 5. Oscillator Dead Time vs. Timing Capacitor

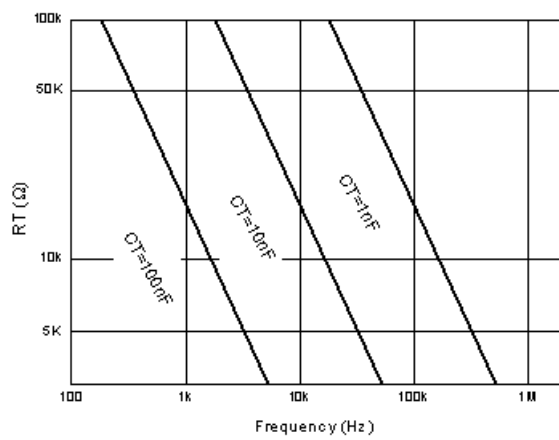

Figure 6. Timing Resistor vs. Frequency

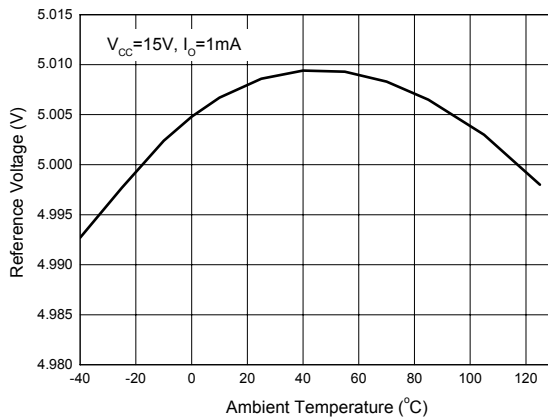

Figure 7. Reference Voltage vs. Ambient Temperature

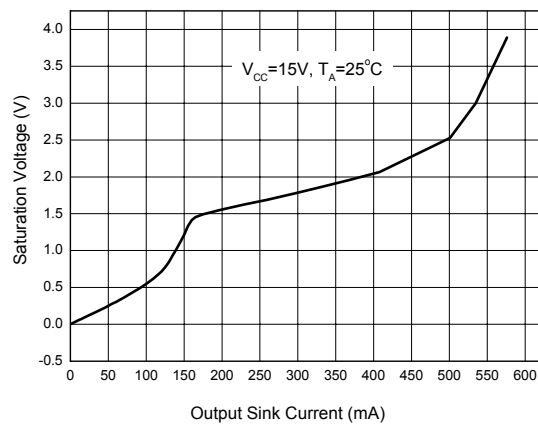

Figure 8. Output Saturation Characteristics



Typical Performance Characteristics (Continued)

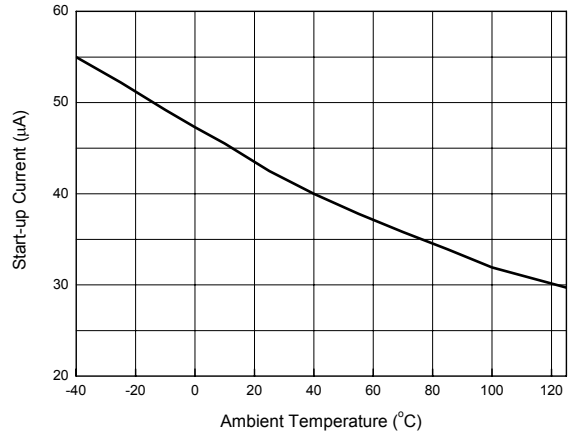
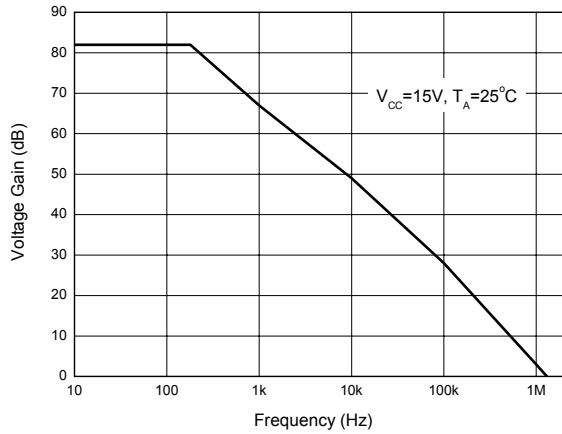

Figure 9. Error Amplifier Open-Loop Frequency Response

Figure 10. Start-up Current vs. Ambient Temperature

CURRENT MODE PWM CONTROLLER

AP384XC

Typical Application

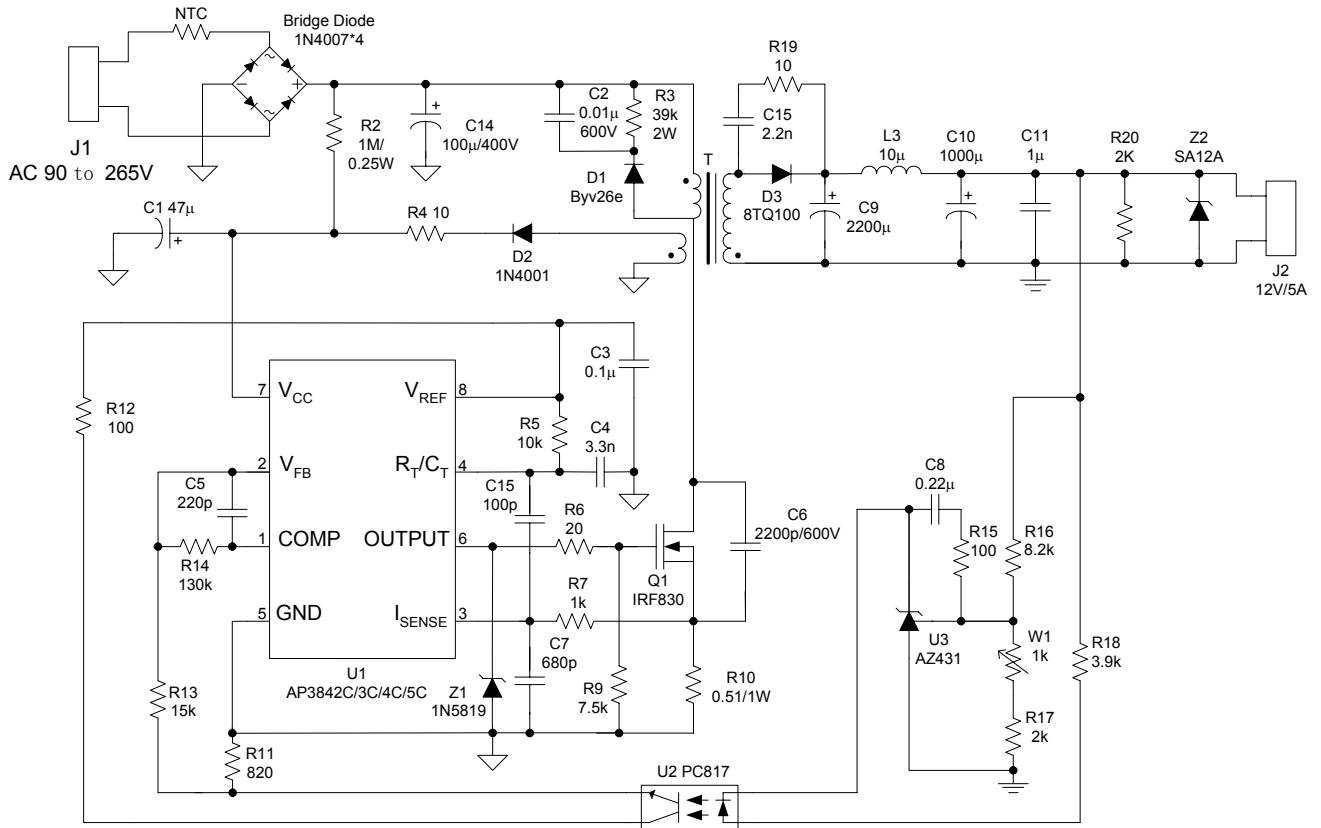

Figure 11. Typical Application of AP3842C/3C/4C/5C



CURRENT MODE PWM CONTROLLER

AP384XC

Mechanical Dimensions

SOIC-8

Unit: mm(inch)

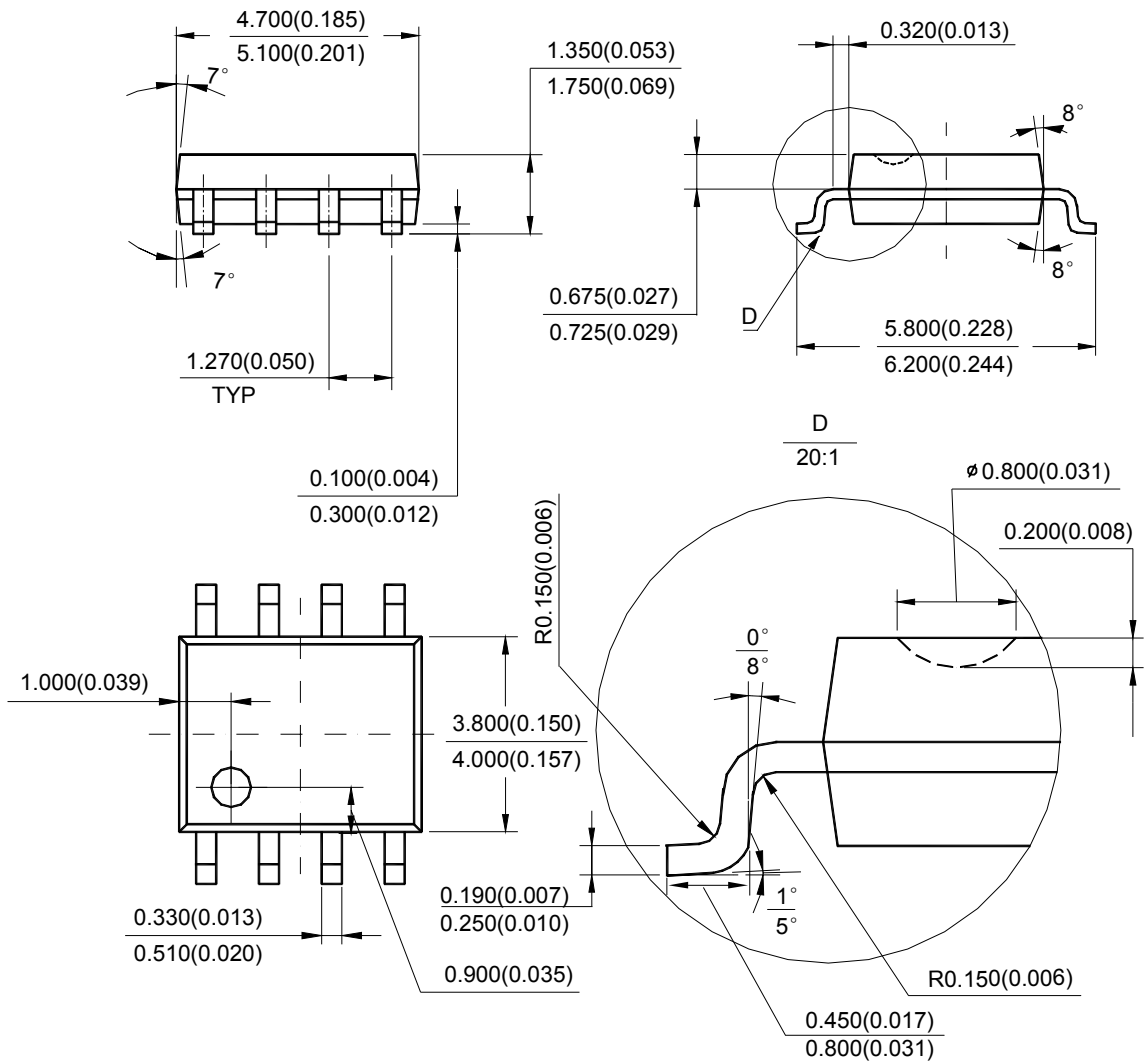

Note: Eject hole, oriented hole and mold mark is optional.



CURRENT MODE PWM CONTROLLER

AP384XC

Mechanical Dimensions (Continued)

DIP-8

Unit: mm(inch)

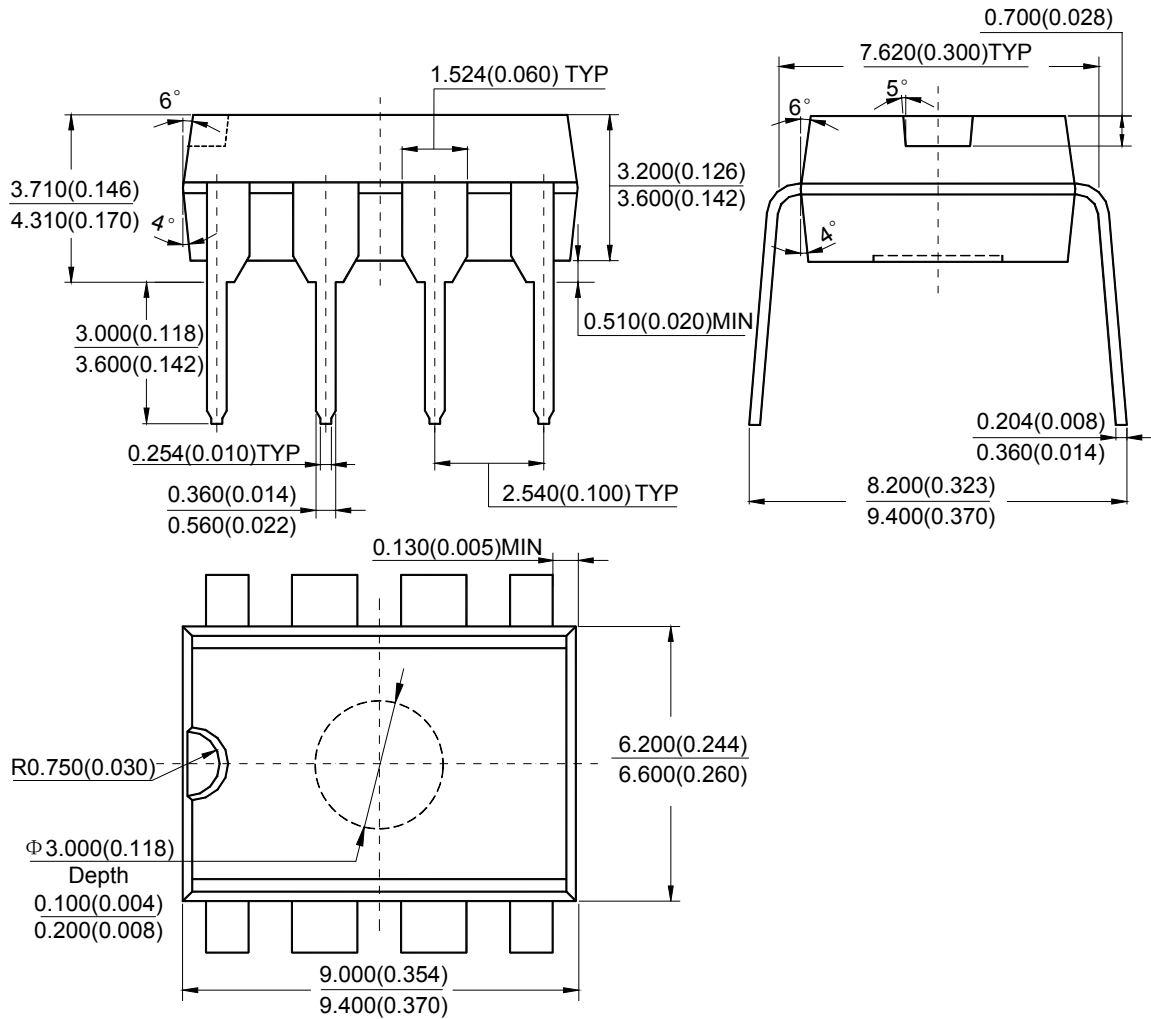

Note: Eject hole, oriented hole and mold mark is optional.

