

CONSTANT VOLTAGE AND CONSTANT CURRENT CONTROLLER**AP4305****General Description**

The AP4305 is a highly integrated solution for a constant voltage/constant current mode SMPS application.

The AP4305 contains one 1.21V voltage reference with $\pm 0.5\%$ accuracy, one current sensing circuit and two operational amplifiers. Combining the voltage reference with one operational amplifier makes AP4305 an ideal voltage controller for use in adapters and battery chargers. The other low voltage reference combined with the other operational amplifier makes it an ideal current limiter for output low side current sensing.

The AP4305 is available in SOT-23-6 package.

Features

- Constant Voltage and Constant Current Control
- Precision Internal Voltage Reference
- Few External Components
- Easy Compensation
- Low Supply Current: 0.5mA
- Operating Temperature Range: -40 to 105°C

Applications

- Adapters
- Battery Chargers

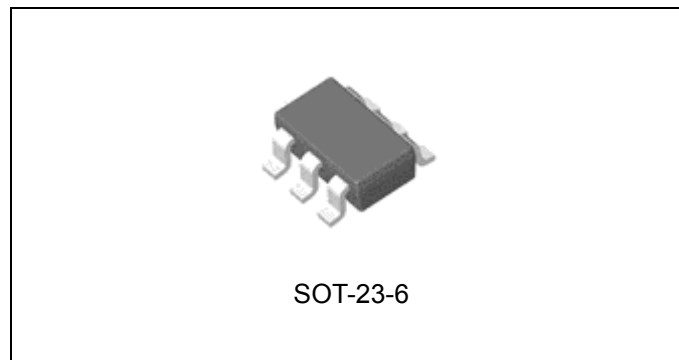

Figure 1. Package Type of AP4305

CONSTANT VOLTAGE AND CONSTANT CURRENT CONTROLLER AP4305
Pin Configuration

Figure 2. Pin Configuration of AP4305 (Top View)

Pin Description

Pin Number	Pin Name	Function
1	V_{CTRL}	Input pin of the voltage control loop
2	GND	Ground
3	V_{OUT}	Output pin. Sinking current only
4	I_{CTRL}	Input pin of the current control loop
5	V_{SENSE}	Input pin of the current control loop
6	V_{CC}	Power supply

CONSTANT VOLTAGE AND CONSTANT CURRENT CONTROLLER AP4305

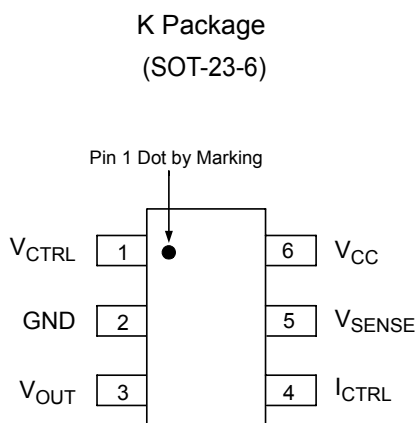
Functional Block Diagram

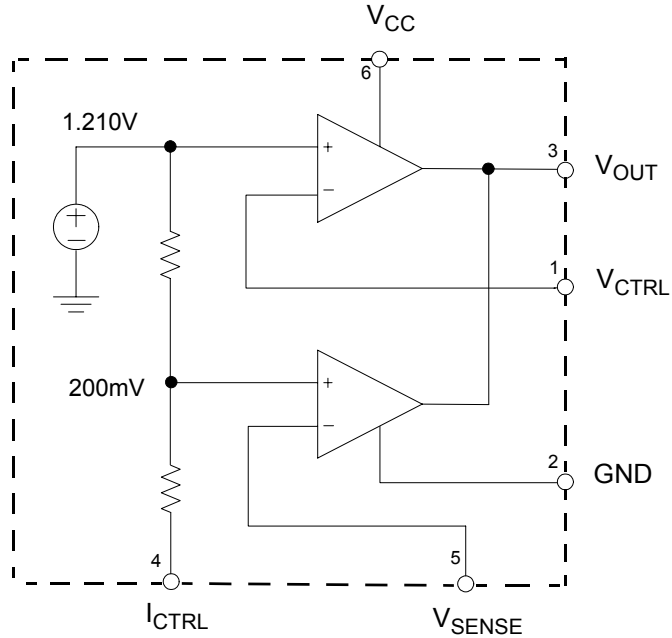
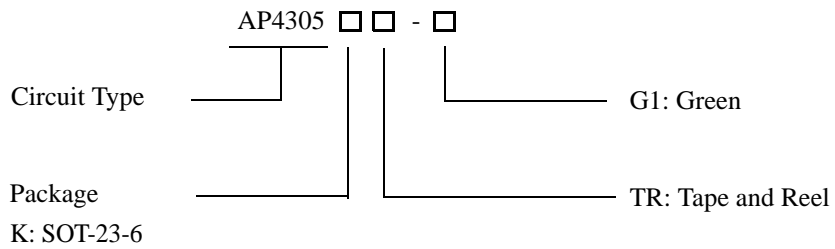

Figure 3. Functional Block Diagram of AP4305

Ordering Information



Package	Temperature Range	Part Number	Marking ID	Packing Type
SOT-23-6	-40 to 105°C	AP4305KTR-G1	G2B	Tape & Reel

BCD Semiconductor's products, as designated with "G1" suffix in the part number, are RoHS compliant and Green.

**CONSTANT VOLTAGE AND CONSTANT CURRENT CONTROLLER AP4305****Absolute Maximum Ratings (Note 1)**

Parameter	Symbol	Value	Unit
Power Supply Voltage	V_{CC}	20	V
Input Voltage	V_{IN}	-0.3 to V_{CC}	V
Junction Temperature	T_J	150	°C
Storage Temperature	T_{STG}	-65 to 150	°C
Lead Temperature (Soldering, 5sec)	T_{LEAD}	260	°C
Package Thermal Resistance (Junction to Case)	θ_{JC}	92	°C/W

Note 1: Stresses greater than those listed under "Absolute Maximum Ratings" may cause permanent damage to the device. These are stress ratings only, and functional operation of the device at these or any other conditions beyond those indicated under "Recommended Operating Conditions" is not implied. Exposure to "Absolute Maximum Ratings" for extended periods may affect device reliability.

Recommended Operating Conditions

Parameter	Symbol	Min	Max	Unit
Power Supply Voltage	V_{CC}	2.5	18	V
Operating Temperature Range	T_A	-40	105	°C



CONSTANT VOLTAGE AND CONSTANT CURRENT CONTROLLER AP4305

Electrical Characteristics

($V_{CC}=5V$, $T_A=25^{\circ}C$, unless otherwise specified.)

Parameter	Symbol	Conditions	Min	Typ	Max	Unit
TOTAL CURRENT CONSUMPTION						
Total Supply Current Not Including the Output Sinking Current	I_{CC}	$T_A=25^{\circ}C$		0.5	1	mA
		$-40^{\circ}C < T_A < 105^{\circ}C$		0.6		
VOLTAGE CONTROL LOOP						
Transconductance Gain (V_{CTRL}). Sink Current Only	G_{mv}	$T_A=25^{\circ}C$	1	3.5		mA/mV
		$-40^{\circ}C < T_A < 105^{\circ}C$		2.5		
Voltage Control Loop Reference	V_{REF}	$T_A=25^{\circ}C$	1.204	1.21	1.216	V
		$-40^{\circ}C < T_A < 105^{\circ}C$	1.186		1.234	
Input Bias Current (V_{CTRL})	I_{IBV}	$T_A=25^{\circ}C$		50		nA
		$-40^{\circ}C < T_A < 105^{\circ}C$		100		
CURRENT CONTROL LOOP						
Transconductance Gain (I_{CTRL}). Sink Current Only	G_{mi}	$T_A=25^{\circ}C$	1.5	7		mA/mV
Current Control Loop Reference	V_{SENSE}	$I_{OUT}=2.5mA$, $T_A=25^{\circ}C$	198	200	202	mV
		$I_{OUT}=2.5mA$, $-40^{\circ}C < T_A < 105^{\circ}C$	192		208	
Current Out of Pin I_{CTRL} at 200mV	I_{IBI}	$T_A=25^{\circ}C$		25		μA
		$-40^{\circ}C < T_A < 105^{\circ}C$		50		
OUTPUT STAGE						
Low Output Voltage at 10mA Sinking Current	V_{OL}	$T_A=25^{\circ}C$		200		mV
Output Short Circuit Current. Output to V_{CC} , Sink Current Only	I_{OS}	$T_A=25^{\circ}C$		27	50	mA
		$-40^{\circ}C < T_A < 105^{\circ}C$		35		



CONSTANT VOLTAGE AND CONSTANT CURRENT CONTROLLER AP4305

Typical Performance Characteristics

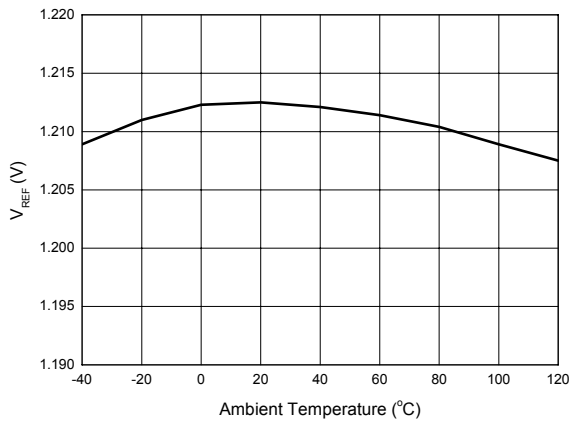

Figure 4. V_{REF} vs. Ambient Temperature

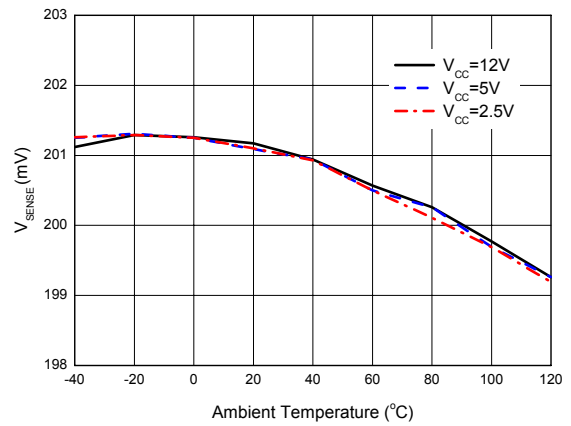

Figure 5. V_{SENSE} vs. Ambient Temperature

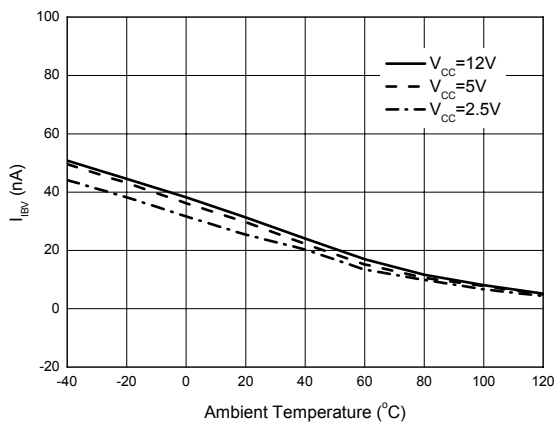

Figure 6. I_{IBV} vs. Ambient Temperature

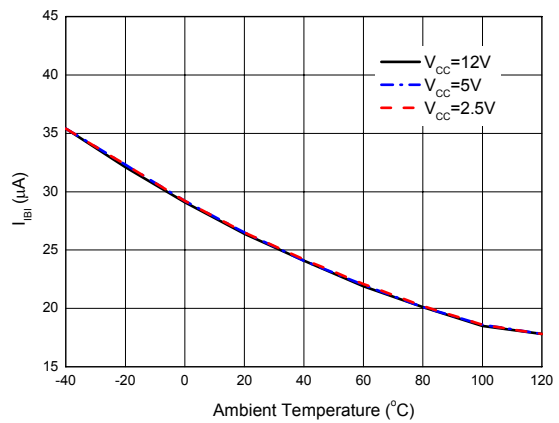

Figure 7. I_{IBI} vs. Ambient Temperature



CONSTANT VOLTAGE AND CONSTANT CURRENT CONTROLLER AP4305

Typical Performance Characteristics (Continued)

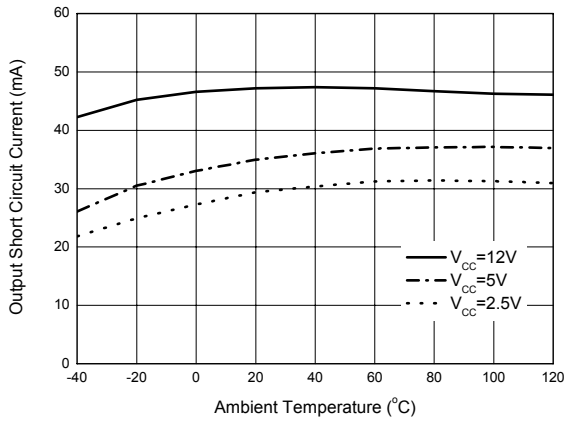

Figure 8. Output Short Circuit Current vs. Ambient Temperature

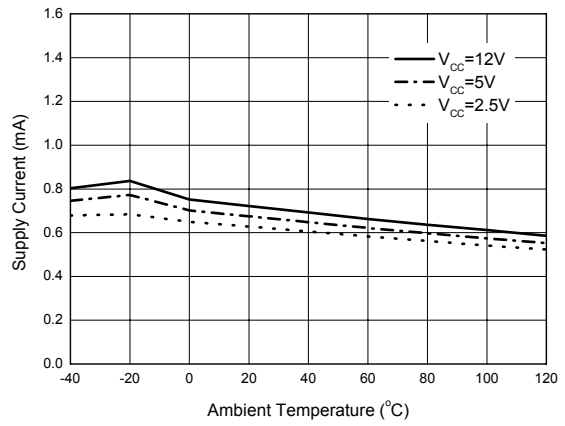
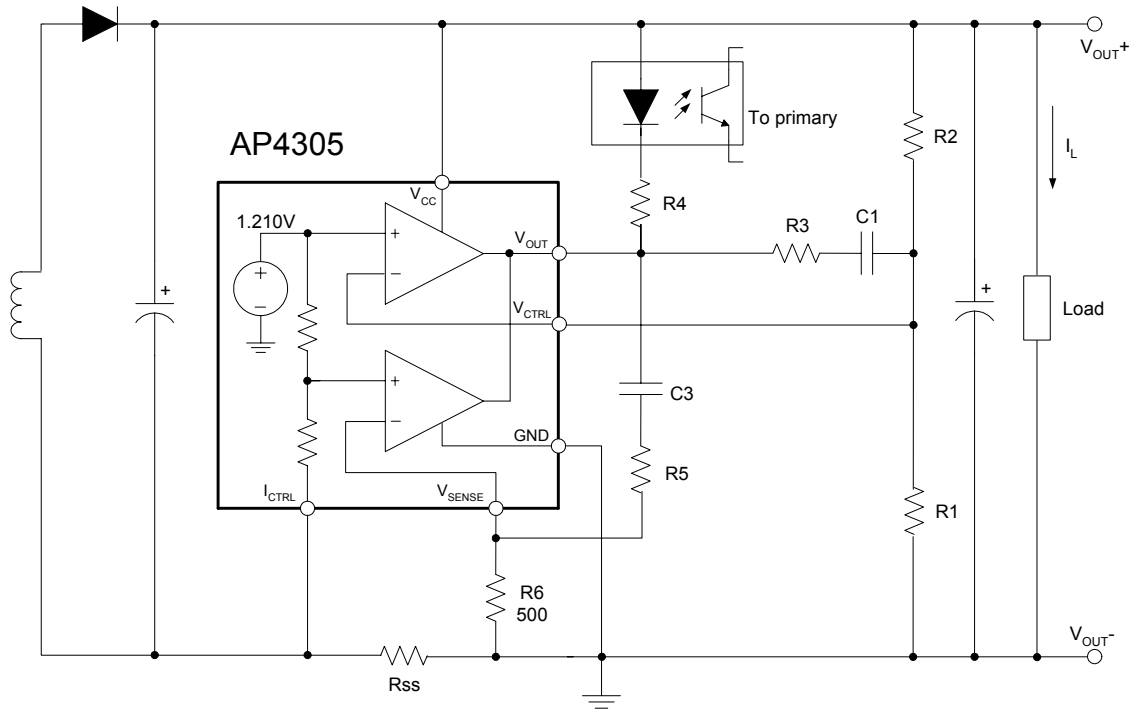

Figure 9. Supply Current vs. Ambient Temperature

CONSTANT VOLTAGE AND CONSTANT CURRENT CONTROLLER AP4305

Typical Application



$$V_{OUT} = V_{REF} \times \frac{R1 + R2}{R1} \quad (V)$$

$$CurrentLimit = \frac{V_{SENSE}}{R_{SS}} \quad (A)$$

Figure 10. Typical Application 1 of AP4305

CONSTANT VOLTAGE AND CONSTANT CURRENT CONTROLLER AP4305

Typical Application (Continued)

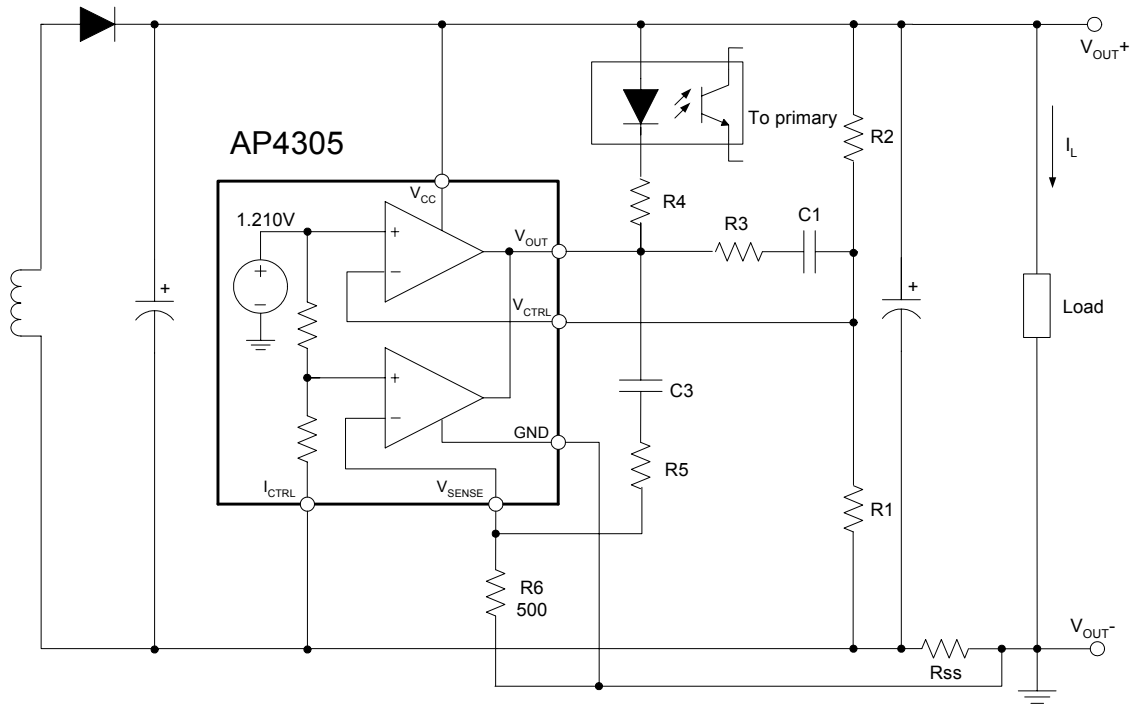

$$V_{OUT} = [V_{REF} + (I_L \times R_{SS})] \times \frac{R1 + R2}{R1} - (I_L \times R_{SS}) \quad (\text{V})$$

$$CurrentLimit = \frac{V_{SENSE}}{R_{SS}} \quad (\text{A})$$

Figure 11. Typical Application 2 of AP4305

CONSTANT VOLTAGE AND CONSTANT CURRENT CONTROLLER AP4305

Typical Application (Continued)

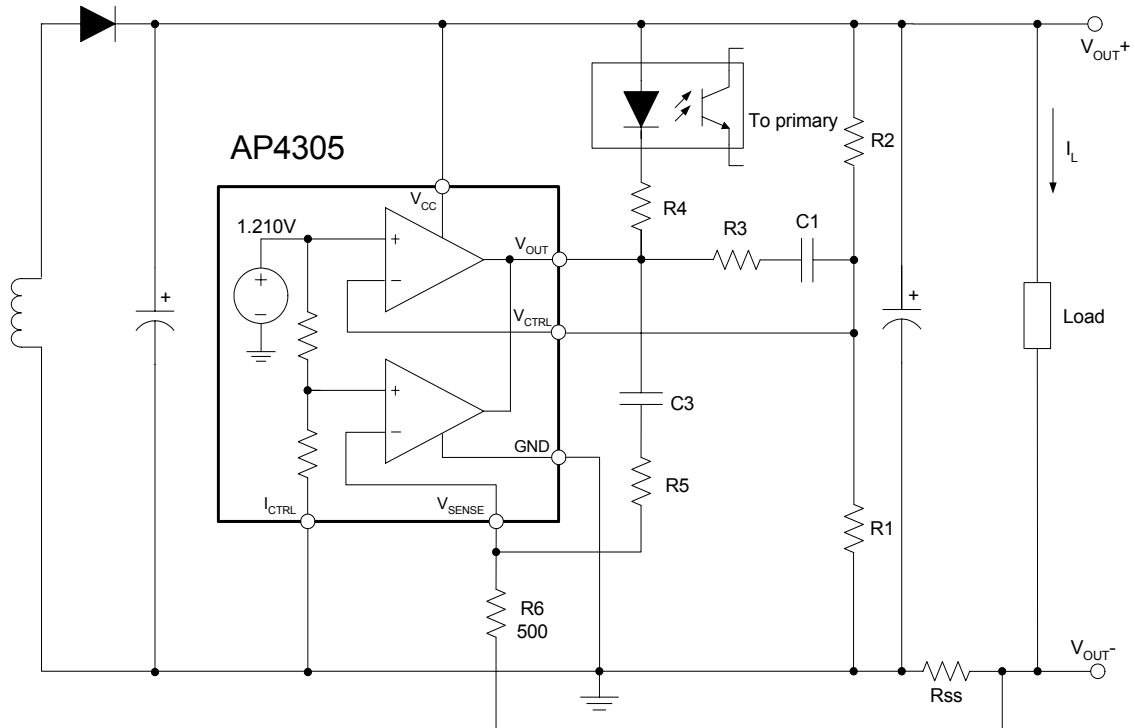

$$V_{OUT} = V_{REF} \times \frac{R1 + R2}{R1} - (I_L \times R_{SS}) \quad (V)$$

$$CurrentLimit = \frac{V_{SENSE} \times V_{REF}}{(V_{SENSE} + V_{REF}) \times R_{SS}} \quad (A)$$

Figure 12. Typical Application 3 of AP4305



CONSTANT VOLTAGE AND CONSTANT CURRENT CONTROLLER AP4305

Mechanical Dimensions

SOT-23-6

Unit: mm(inch)

