



General Description

The AP4306 is a highly integrated solution for a constant voltage/constant current mode SMPS application.

The AP4306 contains one 1.21V voltage reference, one low voltage reference used in current sensing circuit and two operational amplifiers. The 1.21V voltage reference, combined with one operational amplifier, makes of an ideal voltage controller for use in adapters and battery chargers. The low voltage reference, combined with another operational amplifier, makes of an ideal current limiter for output low side current sensing.

The AP4306 is fully compatible with AP4305 in functionality and electrical characteristics except its lower reference voltage for current control loop, thus higher power efficiency in SMPS applications such as low power charger can be realized with AP4306 compared to AP4305.

The AP4306 is available in SOT-23-6 package.

Features

- Constant Voltage and Constant Current Control
- Precision Internal Voltage Reference
- Low External Component Count
- Easy Compensation
- Low Supply Current: 0.5mA
- Current Control Loop Reference
 - A Version: 70mV
 - B Version: 100mV
 - C Version: 150mV
- Operating Temperature Range: -40 to 105°C
- Operating Supply Voltage: 2.5V to 18V

Applications

- Adapters
- Battery Chargers

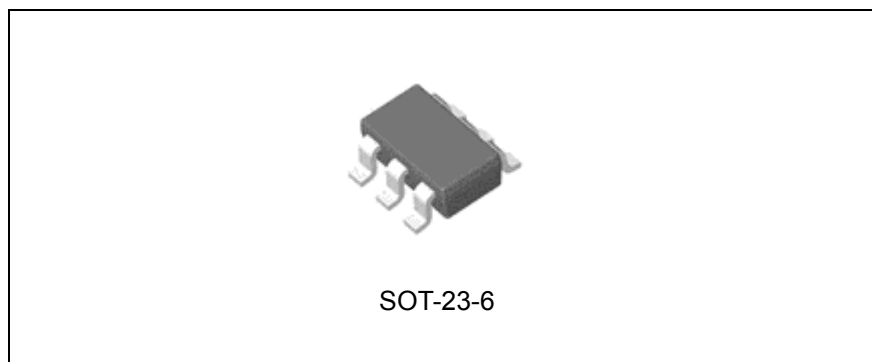

Figure 1. Package Type of AP4306

CONSTANT VOLTAGE AND CONSTANT CURRENT CONTROLLER AP4306
Pin Configuration

Figure 2. Pin Configuration of AP4306 (Top View)

Pin Description

Pin Number	Pin Name	Function
1	V_{CTRL}	Input pin of the voltage control loop.
2	GND	Ground.
3	V_{OUT}	Output pin. Sinking current only.
4	I_{CTRL}	Input pin of the current control loop.
5	V_{SENSE}	Input pin of the current control loop.
6	V_{CC}	Power supply.

CONSTANT VOLTAGE AND CONSTANT CURRENT CONTROLLER AP4306

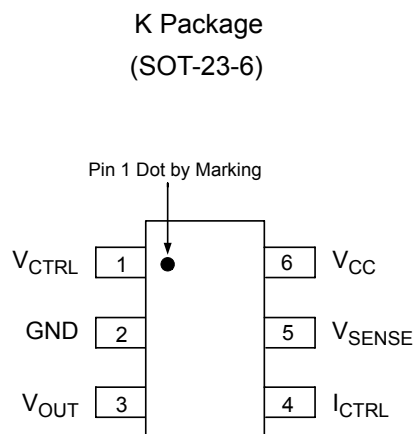
Functional Block Diagram

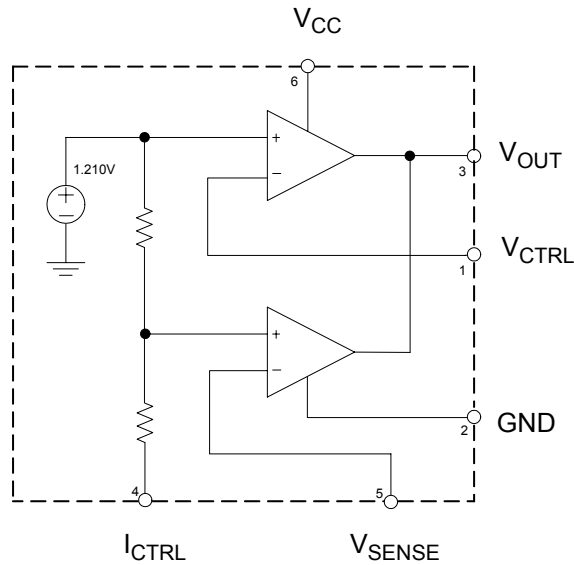

For A, B, C Versions

Figure 3. Functional Block Diagram of AP4306

Ordering Information

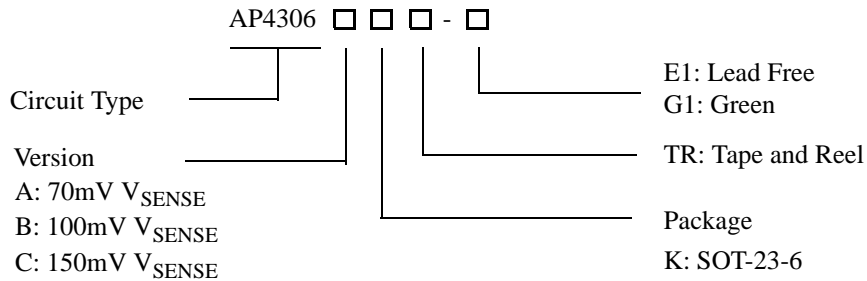

Package	Version	Part Number		Marking ID		Packing Type
		Lead Free	Green	Lead Free	Green	
SOT-23-6	70mV V_{SENSE}	AP4306AKTR-E1	AP4306AKTR-G1	E7L	G7L	Tape & Reel
	100mV V_{SENSE}	AP4306BKTR-E1	AP4306BKTR-G1	E7M	G7M	Tape & Reel
	150mV V_{SENSE}	AP4306CKTR-E1	AP4306CKTR-G1	E7N	G7N	Tape & Reel

BCD Semiconductor's Pb-free products, as designated with "E1" suffix in the part number, are RoHS compliant. Products with "G1" suffix are available in green package.

**CONSTANT VOLTAGE AND CONSTANT CURRENT CONTROLLER AP4306****Absolute Maximum Ratings (Note 1)**

Parameter	Symbol	Value	Unit
Power Supply Voltage	V_{CC}	20	V
Input Voltage	V_{IN}	-0.3 to V_{CC}	V
Junction Temperature	T_J	150	°C
Storage Temperature	T_{STG}	-65 to 150	°C
Lead Temperature (Soldering, 5sec)	T_{LEAD}	260	°C
Thermal Resistance (Junction to Ambient)	SOT-23-6 θ_{JA}	250	°C/W

Note 1: Stresses greater than those listed under "Absolute Maximum Ratings" may cause permanent damage to the device. These are stress ratings only, and functional operation of the device at these or any other conditions beyond those indicated under "Recommended Operating Conditions" is not implied. Exposure to "Absolute Maximum Ratings" for extended periods may affect device reliability.

Recommended Operating Conditions

Parameter	Symbol	Min	Max	Unit
Power Supply Voltage	V_{CC}	2.5	18	V
Operating Temperature Range	T_A	-40	105	°C



CONSTANT VOLTAGE AND CONSTANT CURRENT CONTROLLER AP4306

Electrical Characteristics

($V_{CC}=5V$, $T_A=25^{\circ}C$, unless otherwise specified.)

Parameter	Symbol	Conditions	Min	Typ	Max	Unit
TOTAL CURRENT CONSUMPTION						
Total Supply Current Not Including the Output Sinking	I_{CC}	$T_A=25^{\circ}C$		0.5	1	mA
		$-40^{\circ}C < T_A < 105^{\circ}C$		0.6		
VOLTAGE CONTROL LOOP						
Transconductance Gain (V_{CTRL}). Sink Current Only	G_{mv}	$T_A=25^{\circ}C$	1	3.5		mA/mV
		$-40^{\circ}C < T_A < 105^{\circ}C$		2.5		
Voltage Control Loop Reference	V_{REF}	A Version	$T_A=25^{\circ}C$	1.186	1.21	1.234
			$-40^{\circ}C < T_A < 105^{\circ}C$	1.162		1.258
		B, C Versions	$T_A=25^{\circ}C$	1.204	1.21	1.216
			$-40^{\circ}C < T_A < 105^{\circ}C$	1.186		1.234
Input Bias Current (V_{CTRL})	I_{IBV}	$T_A=25^{\circ}C$		50		nA
		$-40^{\circ}C < T_A < 105^{\circ}C$		100		
CURRENT CONTROL LOOP						
Transconductance Gain (I_{CTRL}). Sink Current Only	G_{mi}	$T_A=25^{\circ}C$	1.5	7		mA/mV
		$-40^{\circ}C < T_A < 105^{\circ}C$		1.5	7	
Current Control Loop Reference	V_{SENSE}	A Version	$T_A=25^{\circ}C$	66.5	70	73.5
			$-40^{\circ}C < T_A < 105^{\circ}C$	63		77
		B Version	$T_A=25^{\circ}C$	97	100	103
			$-40^{\circ}C < T_A < 105^{\circ}C$	94		106
		C Version	$T_A=25^{\circ}C$	147	150	153
			$-40^{\circ}C < T_A < 105^{\circ}C$	143		157
Current Out of Pin I_{CTRL} at V_{SENSE}	I_{IBI}	A Version	$T_A=25^{\circ}C$		18	μA
			$-40^{\circ}C < T_A < 105^{\circ}C$		35	
		B Version	$T_A=25^{\circ}C$		25	
			$-40^{\circ}C < T_A < 105^{\circ}C$		50	
		C Version	$T_A=25^{\circ}C$		37.5	
			$-40^{\circ}C < T_A < 105^{\circ}C$		75	
OUTPUT STAGE						
Low Output Voltage at 10mA Sinking Current	V_{OL}	$T_A=25^{\circ}C$		100		mV
		$-40^{\circ}C < T_A < 105^{\circ}C$		100		
Output Short Circuit Current. Output to V_{CC} . Sink Current Only	I_{OS}	$T_A=25^{\circ}C$		27	50	mA
		$-40^{\circ}C < T_A < 105^{\circ}C$		35		

Thermal Impedance

Parameter	Symbol	Value	Unit
Thermal Resistance (Junction to Case)	θ_{JC}	84	$^{\circ}C/W$



CONSTANT VOLTAGE AND CONSTANT CURRENT CONTROLLER AP4306

Typical Performance Characteristics

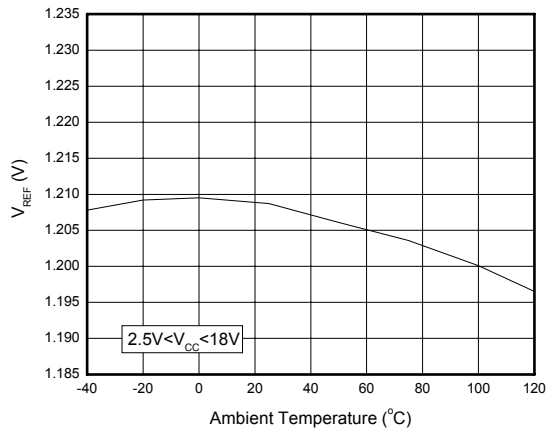

Figure 4. AP4306 V_{REF} vs. Ambient Temperature

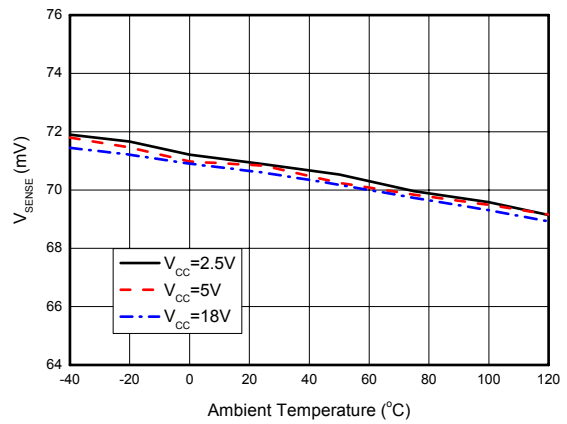

Figure 5. AP4306A V_{SENSE} vs. Ambient Temperature

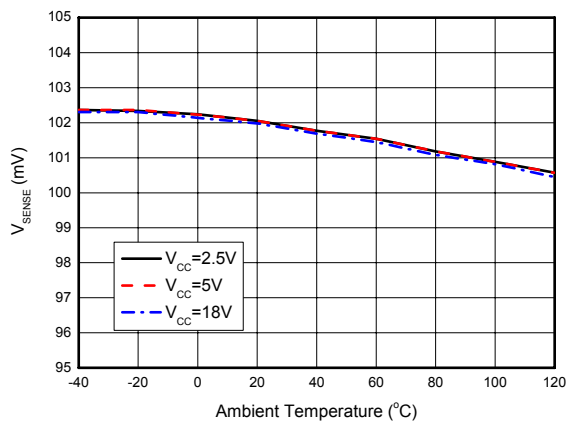

Figure 6. AP4306B V_{SENSE} vs. Ambient Temperature

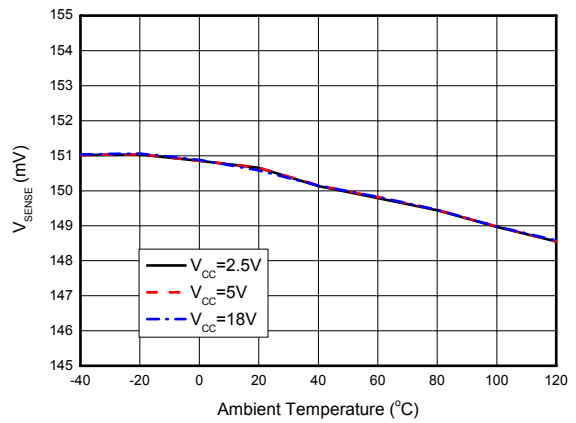

Figure 7. AP4306C V_{SENSE} vs. Ambient Temperature



CONSTANT VOLTAGE AND CONSTANT CURRENT CONTROLLER AP4306

Typical Performance Characteristics (Continued)

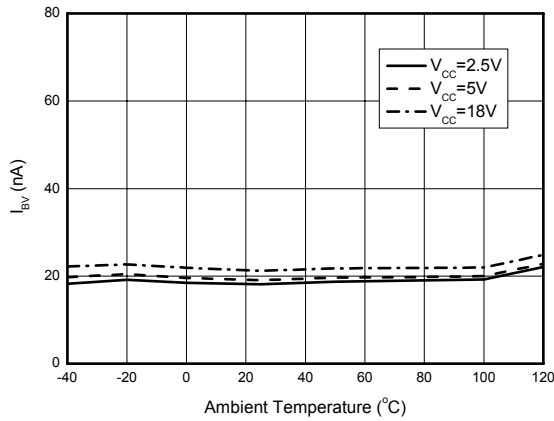

Figure 8. AP4306 I_{BV} vs. Ambient Temperature

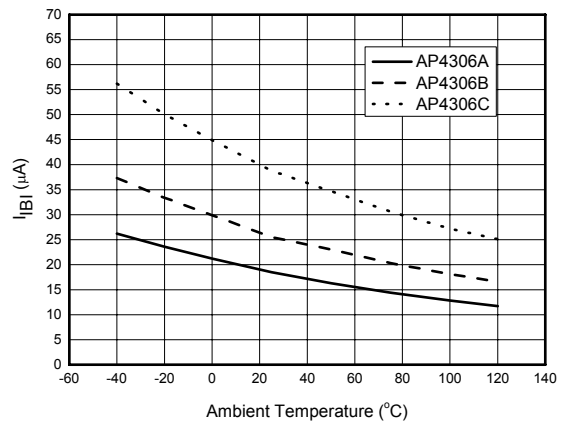

Figure 9. AP4306 I_{BI} vs. Ambient Temperature

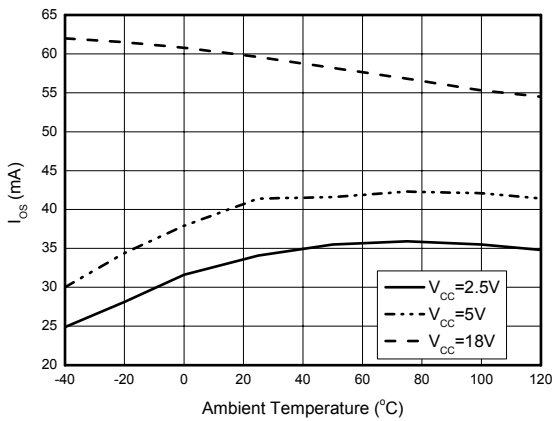

Figure 10. AP4306 I_{OS} vs. Ambient Temperature

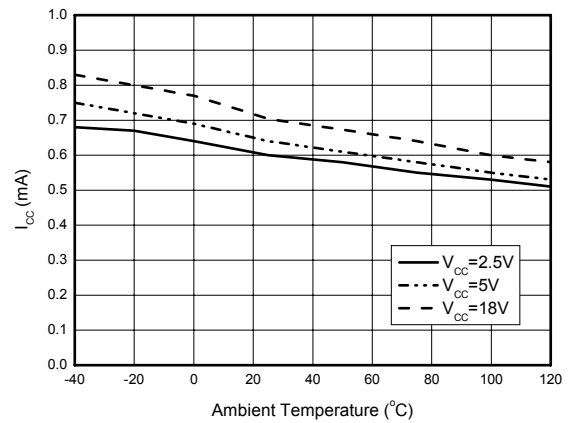
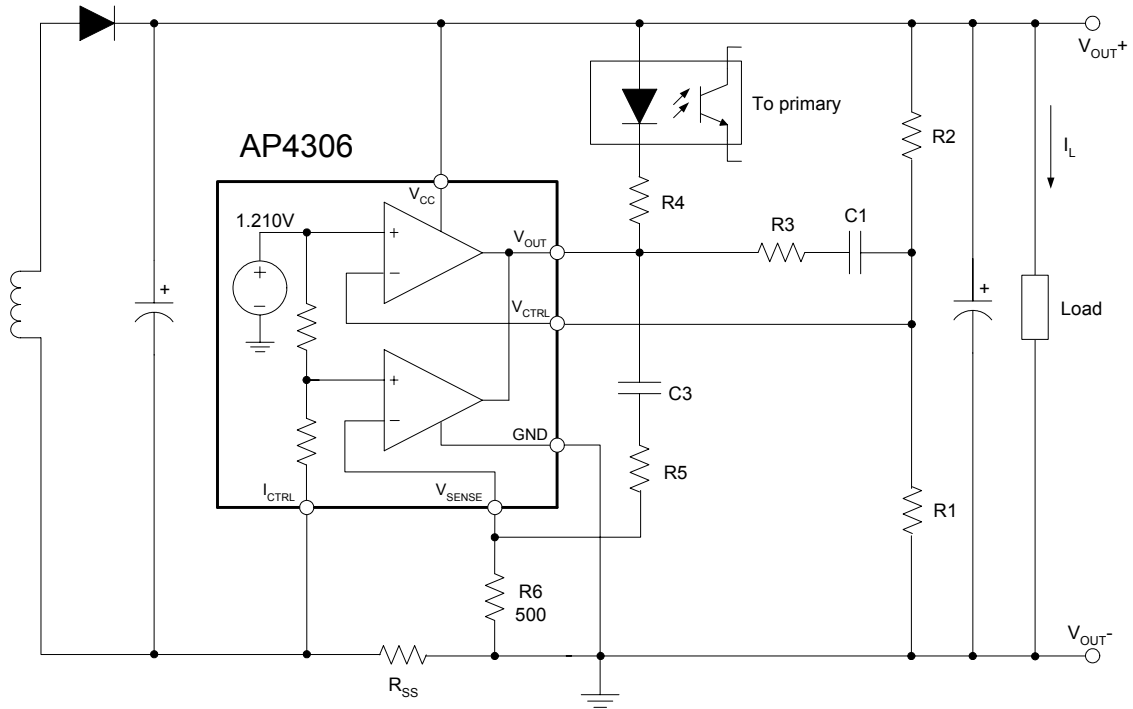

Figure 11. AP4306 I_{CC} vs. Ambient Temperature

CONSTANT VOLTAGE AND CONSTANT CURRENT CONTROLLER AP4306

Typical Application



$$V_{OUT} = V_{REF} \times \frac{R1 + R2}{R1} \quad (V)$$

$$CurrentLimit = \frac{V_{SENSE}}{R_{SS}} \quad (A)$$

Figure 12. Typical Application 1 of AP4306



CONSTANT VOLTAGE AND CONSTANT CURRENT CONTROLLER AP4306

Mechanical Dimensions

SOT-23-6

Unit: mm(inch)

