

**HIGH VOLTAGE FAST SWITCHING NPN POWER TRANSISTOR**

**APT13003E**

**General Description**

The APT13003E series are high voltage, high speed switching NPN Power transistors specially designed for off-line switch mode power supplies with low output power.

The APT13003E series are available in TO-92 and TO-126 packages.

**Features**

- High Switching Speed
- High Collector-Emitter Voltage
- Low Cost
- Bulk and Ammo Packing TO-92 Package and TO-126 Package

**Applications**

- Battery Chargers for Mobile Phone of BCD Solution
- Power Supply for DVD/STB of BCD Solution

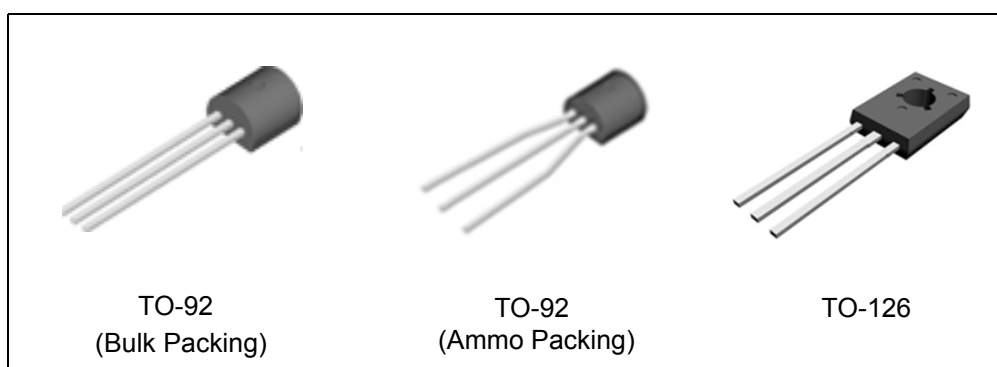
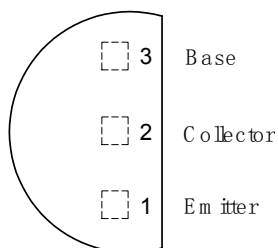

Figure 1. Package Types of APT13003E

**Pin Configuration**

Z Package  
(TO-92(Bulk Packing))



(Top View)

Z Package  
(TO-92(Ammo Packing))

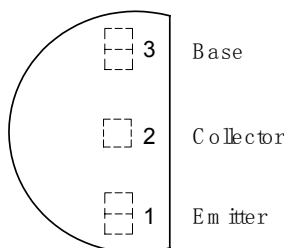

U Package  
(TO-126)

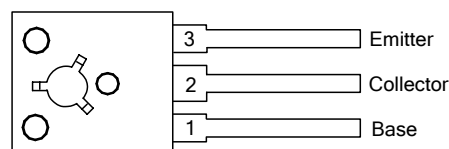

(Front View)

Figure 2. Pin Configurations of APT13003E



**HIGH VOLTAGE FAST SWITCHING NPN POWER TRANSISTOR**

**APT13003E**

**Ordering Information**

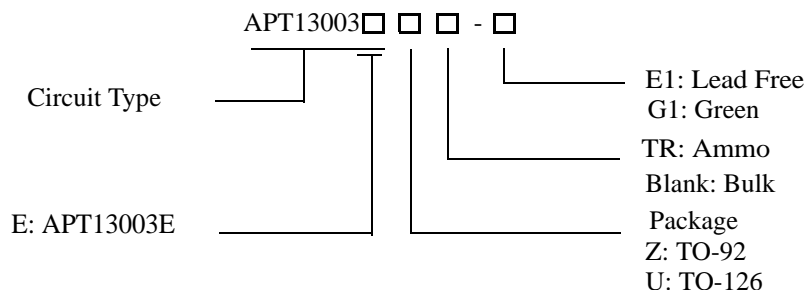

Package	Part Number		Marking ID		Packing Type
	Lead Free	Green	Lead Free	Green	
TO-92	APT13003EZ-E1	APT13003EZ-G1	13003EZ-E1	13003EZ-G1	Bulk
	APT13003EZTR-E1	APT13003EZTR-G1	13003EZ-E1	13003EZ-G1	Ammo
TO-126	APT13003EU-E1	APT13003EU-G1	EU13003E	GU13003E	Bulk

BCD Semiconductor's Pb-free products, as designated with "E1" suffix in the part number, are RoHS compliant. Products with "G1" suffix are available in green packages.

**Absolute Maximum Ratings (Note 1)**

Parameter	Symbol	Value	Unit
Collector-Emitter Voltage ( $V_{BE}=0$ )	$V_{CES}$	700	V
Collector-Emitter Voltage ( $I_B=0$ )	$V_{CEO}$	465	V
Emitter-Base Voltage ( $I_C=0$ )	$V_{EBO}$	9	V
Collector Current	$I_C$	1.5	A
Collector Peak Current (Pulse) (Note 2)	$I_{CM}$	3	A
Base Current	$I_B$	0.75	A
Base Peak Current (Pulse) (Note 2)	$I_{BM}$	1.5	A
Power Dissipation, $T_A=25^\circ\text{C}$	For TO-92	$P_{TOT}$	1.1 W
Power Dissipation, $T_C=25^\circ\text{C}$	For TO-126	$P_{TOT}$	20 W
Operating Junction Temperature	$T_J$	150	$^\circ\text{C}$
Storage Temperature Range	$T_{STG}$	-65 to 150	$^\circ\text{C}$

Note 1: Stresses greater than those listed under "Absolute Maximum Ratings" may cause permanent damage to the device. These are stress ratings only, and functional operation of the device at these or any other conditions beyond those indicated under "Recommended Operating Conditions" is not implied. Exposure to "Absolute Maximum Ratings" for extended periods may affect device reliability.

Note 2: Pulse test for Pulse Width < 5ms, Duty Cycle ≤ 10%.



**HIGH VOLTAGE FAST SWITCHING NPN POWER TRANSISTOR**

**APT13003E**

**Thermal Characteristics**

Parameter		Symbol	Value	Unit
Thermal Resistance (Junction-to-Case)	For TO-92	$\theta_{JC}$	83.3	°C/W
	For TO-126		6.25	
Thermal Resistance (Junction-to-Ambient)	For TO-92	$\theta_{JA}$	113.6	°C/W
	For TO-126		96	

**Electrical Characteristics**

( $T_C=25^\circ\text{C}$ , unless otherwise specified.)

Parameter	Symbol	Conditions	Min	Typ	Max	Unit
Collector Cut-off Current ( $V_{BE}=-1.5\text{V}$ )	$I_{CEV}$	$V_{CE}=700\text{V}$			10	$\mu\text{A}$
Collector-Emitter Sustaining Voltage ( $I_B=0$ )	$V_{CEO}(\text{sus})$	$I_C=100\mu\text{A}$	465			V
Collector-Emitter Saturation Voltage (Note 3)	$V_{CE}(\text{sat})$	$I_C=0.5\text{A}, I_B=0.1\text{A}$		0.17	0.3	V
		$I_C=1.0\text{A}, I_B=0.25\text{A}$		0.29	0.4	
Base-Emitter Saturation Voltage (Note 3)	$V_{BE}(\text{sat})$	$I_C=0.5\text{A}, I_B=0.1\text{A}$			1.0	V
		$I_C=1.0\text{A}, I_B=0.25\text{A}$			1.2	
DC Current Gain (Note 3)	$h_{FE}$	$I_C=0.3\text{A}, V_{CE}=2\text{V}$	15			
		$I_C=0.5\text{A}, V_{CE}=2\text{V}$	13	17	30	
		$I_C=1.0\text{A}, V_{CE}=2\text{V}$	5		25	
Output Capacitance	$C_{ob}$	$V_{CB}=10\text{V}, f=0.1\text{MHz}$		16		pF
Current Gain Bandwidth Product	$f_T$	$V_{CE}=10\text{V}, I_C=0.1\text{A}$	4			MHz
Turn-on Time with Resistive Load	$t_{on}$	$I_C=1\text{A}, V_{CC}=125\text{V}, I_{B1}=0.2\text{A}, I_{B2}=-0.2\text{A}, T_P=25\mu\text{S}$		0.3	1	$\mu\text{S}$
Storage Time with Resistive Load	$t_s$			1.8	3	
Fall Time with Resistive Load	$t_f$			0.28	0.4	

Note 3: Pulse test for Pulse Width  $\leq 300\mu\text{s}$ , Duty Cycle  $\leq 2\%$ .



**Typical Performance Characteristics**

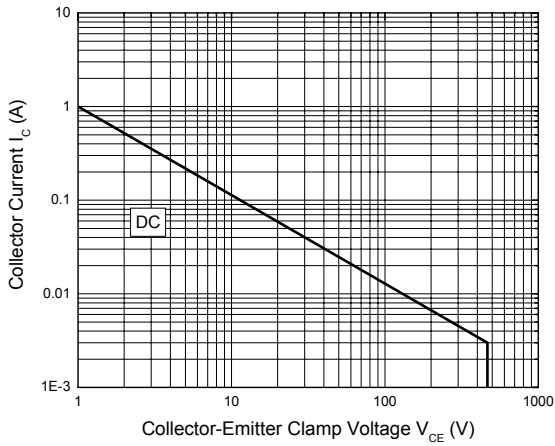

Figure 3. Safe Operating Areas (TO-92 Package)

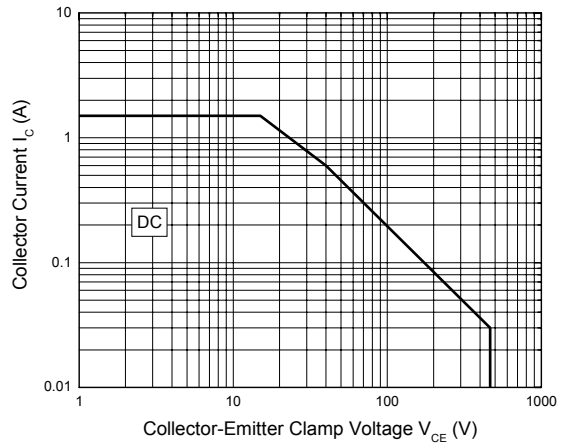

Figure 4. Safe Operating Areas (TO-126 Package)

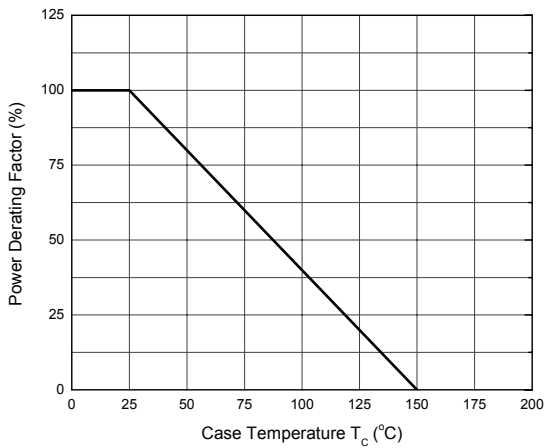

Figure 5. Power Derating Curve

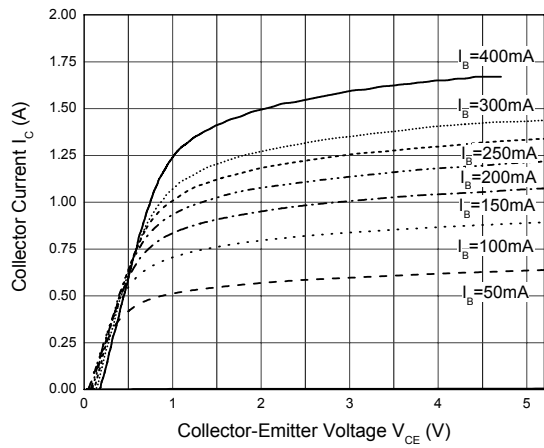

Figure 6. Static Characteristics



**Typical Performance Characteristics (Continued)**

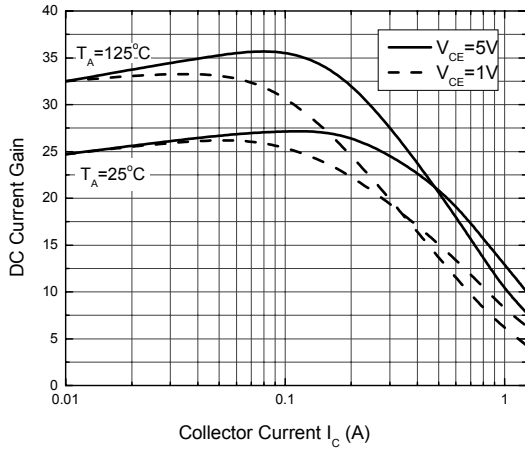

Figure 7. DC Current Gain

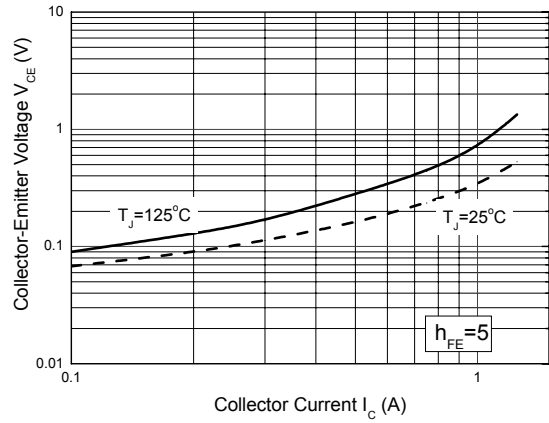

Figure 8. Collector-Emitter Saturation Voltage

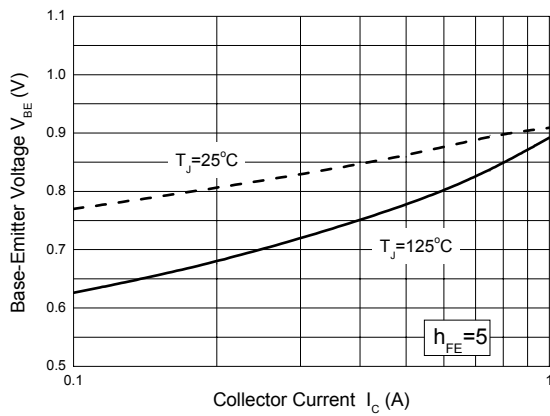

Figure 9. Base-Emitter Saturation Voltage

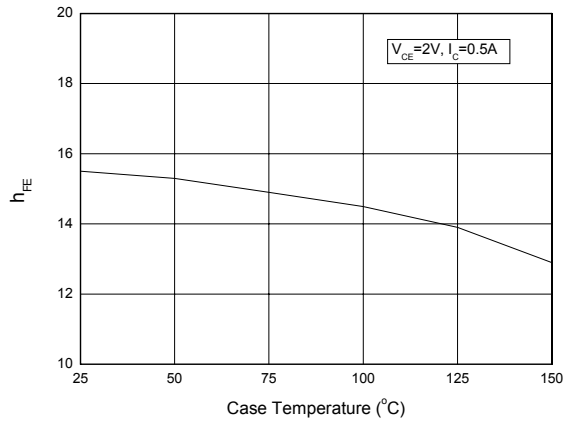

Figure 10.  $h_{FE}$  vs. Case Temperature



Mechanical Dimensions

TO-92 (Bulk Packing)

Unit: mm(inch)

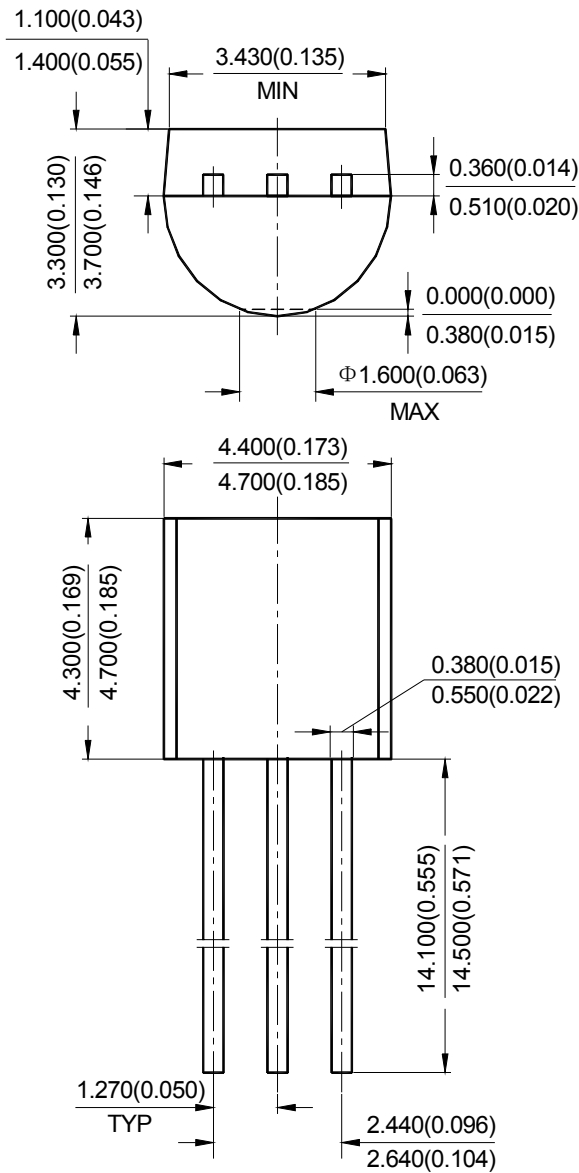



Mechanical Dimensions (Continued)

TO-92 (Ammo Packing)

Unit: mm(inch)

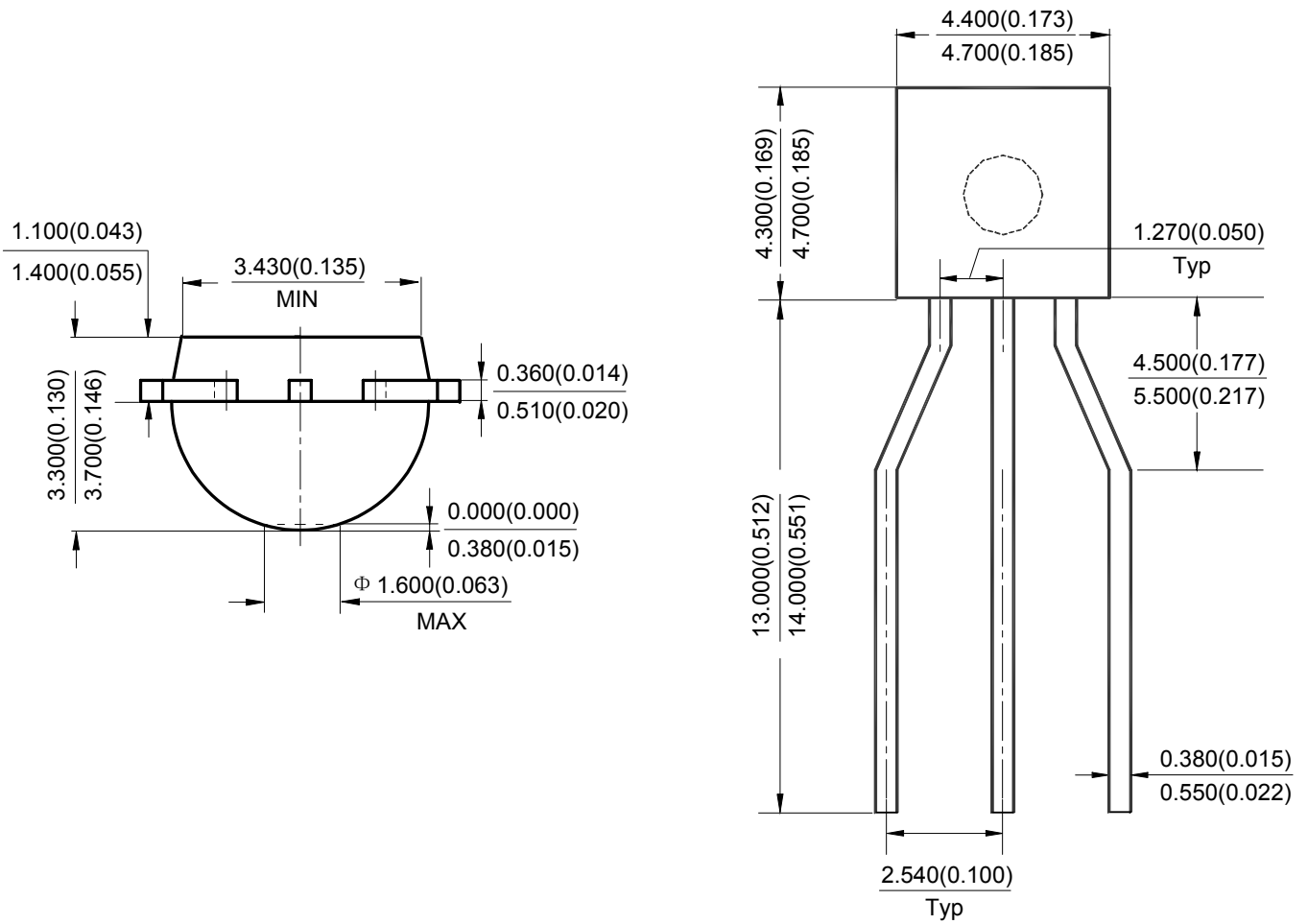



Mechanical Dimensions (Continued)

TO-126

Unit: mm(inch)

