

**HIGH VOLTAGE FAST SWITCHING NPN POWER TRANSISTOR**

**APT13003S**

**General Description**

The APT13003S series are high voltage, high speed switching transistors specially designed for off-line switch mode power supplies with low output power.

The APT13003S series are available in TO-92 and TO-126 packages.

**Features**

- High Switching Speed
- High Collector-Emitter Voltage
- Low Cost
- Bulk and Ammo Packing TO-92 Package and TO-126 Package

**Applications**

- Battery Chargers for Mobile Phone
- Standby Power Supply

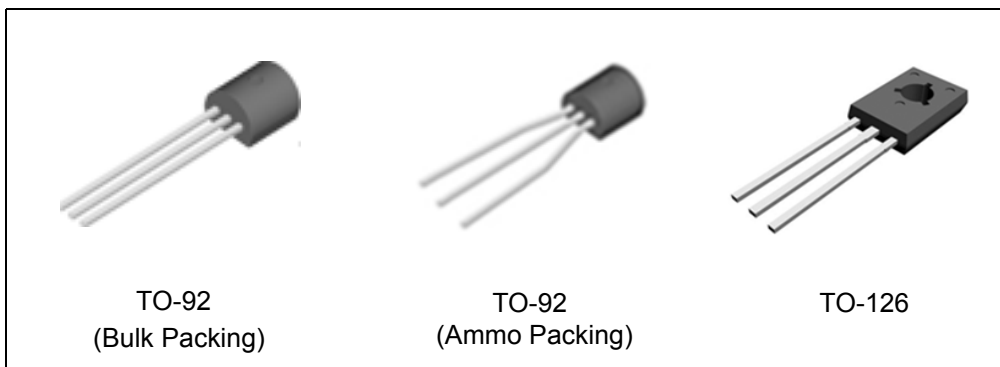
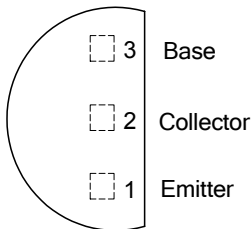

Figure 1. Package Types of APT13003S

**Pin Configuration**

Z Package  
(TO-92(Bulk Packing))



(Top View)

Z Package  
(TO-92(Ammo Packing))

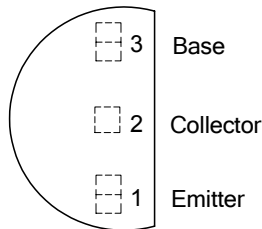

U Package  
(TO-126)

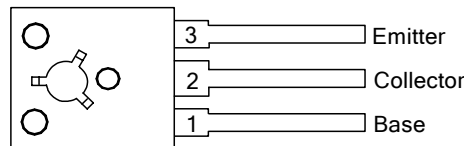

(Front View)

Figure 2. Pin Configurations of APT13003S



**HIGH VOLTAGE FAST SWITCHING NPN POWER TRANSISTOR**

**APT13003S**

**Ordering Information**

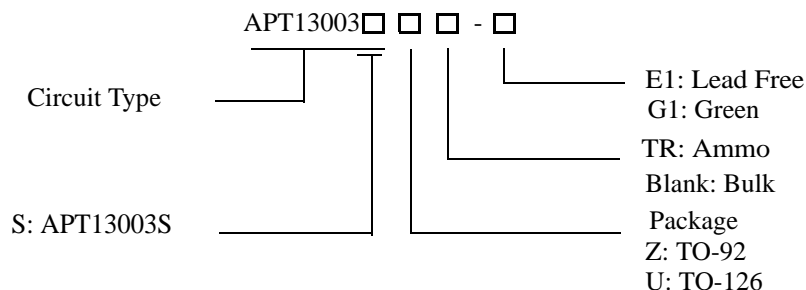

Package	Part Number		Marking ID		Packing Type
	Lead Free	Green	Lead Free	Green	
TO-92		APT13003SZ-G1		13003SZ-G1	Bulk
		APT13003SZTR-G1		13003SZ-G1	Ammo
TO-126	APT13003SU-E1	APT13003SU-G1	EU13003S	GU13003S	Bulk

BCD Semiconductor's Pb-free products, as designated with "E1" suffix in the part number, are RoHS compliant. Products with "G1" suffix are available in green packages.

**Absolute Maximum Ratings (Note 1)**

Parameter	Symbol	Value	Unit	
Collector-Emitter Voltage ( $V_{BE}=0$ )	$V_{CES}$	700	V	
Collector-Emitter Voltage ( $I_B=0$ )	$V_{CEO}$	450	V	
Emitter-Base Voltage ( $I_C=0$ )	$V_{EBO}$	9	V	
Collector Current	$I_C$	1.3	A	
Collector Peak Current (Pulse) (Note 2)	$I_{CM}$	2.6	A	
Base Current	$I_B$	0.65	A	
Base Peak Current (Pulse) (Note 2)	$I_{BM}$	1.3	A	
Power Dissipation, $T_A=25^{\circ}C$	For TO-92	$P_{TOT}$	1.1	W
Power Dissipation, $T_C=25^{\circ}C$	For TO-126	$P_{TOT}$	20	W
Operating Junction Temperature	$T_J$	150	$^{\circ}C$	
Storage Temperature Range	$T_{STG}$	-55 to 150	$^{\circ}C$	

Note 1: Stresses greater than those listed under "Absolute Maximum Ratings" may cause permanent damage to the device. These are stress ratings only, and functional operation of the device at these or any other conditions beyond those indicated under "Recommended Operating Conditions" is not implied. Exposure to "Absolute Maximum Ratings" for extended periods may affect device reliability.

Note 2: Pulse test for Pulse Width < 5ms, Duty Cycle ≤ 10%.

**HIGH VOLTAGE FAST SWITCHING NPN POWER TRANSISTOR****APT13003S****Thermal Characteristics**

Parameter		Symbol	Value	Unit
Thermal Resistance (Junction-to-Case)	For TO-92	$\theta_{JC}$	83.3	$^{\circ}\text{C}/\text{W}$
	For TO-126		6.25	
Thermal Resistance (Junction-to-Ambient)	For TO-92	$\theta_{JA}$	113.6	$^{\circ}\text{C}/\text{W}$
	For TO-126		96	

**Electrical Characteristics**(  $T_C=25^{\circ}\text{C}$ , unless otherwise specified.)

Parameter	Symbol	Conditions	Min	Typ	Max	Unit
Collector Cut-off Current ( $V_{BE}=-1.5\text{V}$ )	$I_{CEV}$	$V_{CE}=700\text{V}$			10	$\mu\text{A}$
Collector-Emitter Sustaining Voltage	$V_{CEO}$ (sus)	$I_C=100\mu\text{A}$	450			V
Collector-Emitter Saturation Voltage (Note 3)	$V_{CE}$ (sat)	$I_C=0.5\text{A}, I_B=0.1\text{A}$			0.3	V
		$I_C=1.0\text{A}, I_B=0.25\text{A}$			0.6	
Base-Emitter Saturation Voltage (Note 3)	$V_{BE}$ (sat)	$I_C=0.5\text{A}, I_B=0.1\text{A}$			1.0	V
		$I_C=1.0\text{A}, I_B=0.25\text{A}$			1.2	
DC Current Gain (Note 3)	$h_{FE}$	$I_C=0.5\text{A}, V_{CE}=2\text{V}$	13		30	
		$I_C=1.0\text{A}, V_{CE}=2\text{V}$	5		25	
Current Gain Bandwidth Product	$f_T$	$V_{CE}=10\text{V}, I_C=0.1\text{A}$	4			MHz
Turn-on Time with Resistive Load	$t_{on}$	$I_C=1\text{A}, V_{CC}=125\text{V}, I_{B1}=0.2\text{A}, I_{B2}=-0.2\text{A}, T_p=25\mu\text{S}$			1.0	$\mu\text{s}$
Storage Time with Resistive Load	$t_s$				3.0	
Fall Time with Resistive Load	$t_f$				0.5	

Note 3: Pulse test for Pulse Width  $\leq 300\mu\text{s}$ , Duty Cycle  $\leq 2\%$ .



**Typical Performance Characteristics**

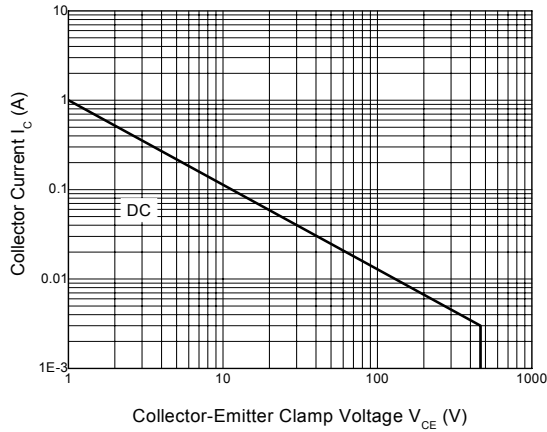

Figure 3. Safe Operating Areas (TO-92 Package)

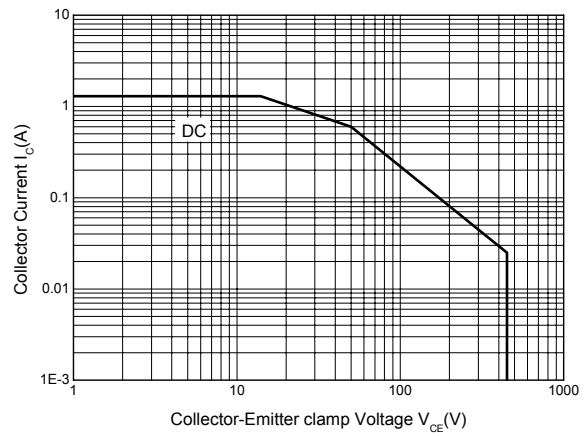

Figure 4. Safe Operating Areas (TO-126 Package)

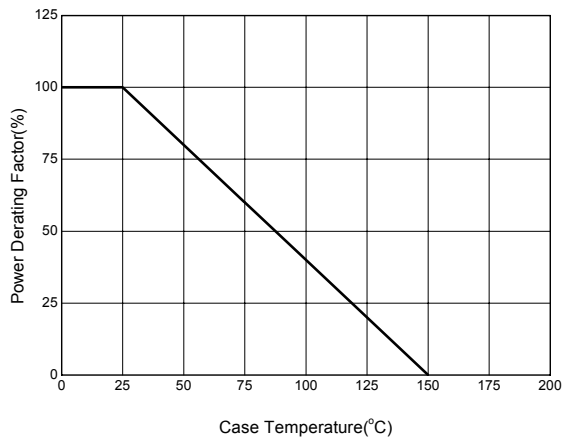

Figure 5. Power Derating Curve

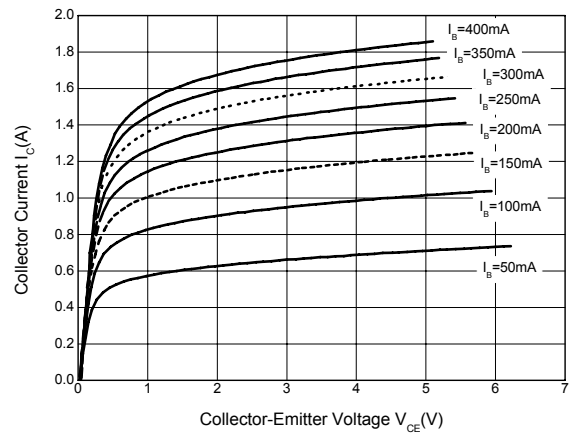

Figure 6. Static Characteristics



Typical Performance Characteristics (Continued)

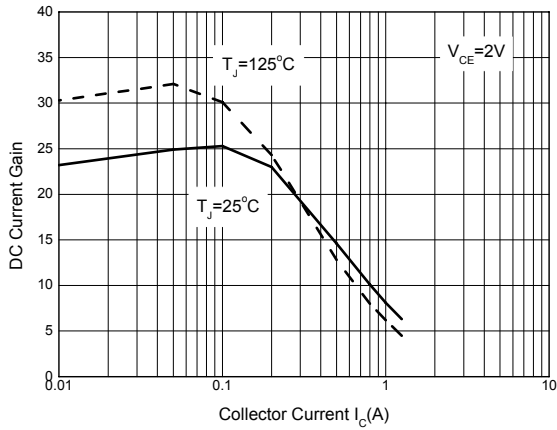

Figure 7. DC Current Gain

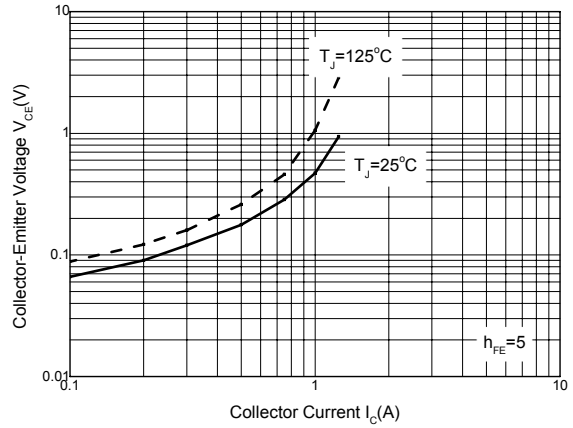

Figure 8. Collector-Emitter Saturation Voltage

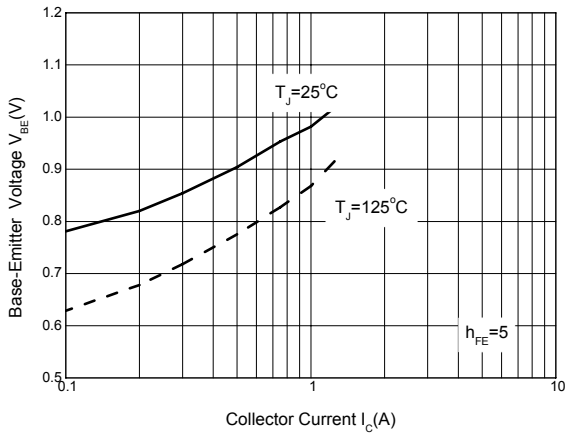

Figure 9. Base-Emitter Saturation Voltage



**Mechanical Dimensions**

**TO-92 (Bulk Packing)**

**Unit: mm(inch)**

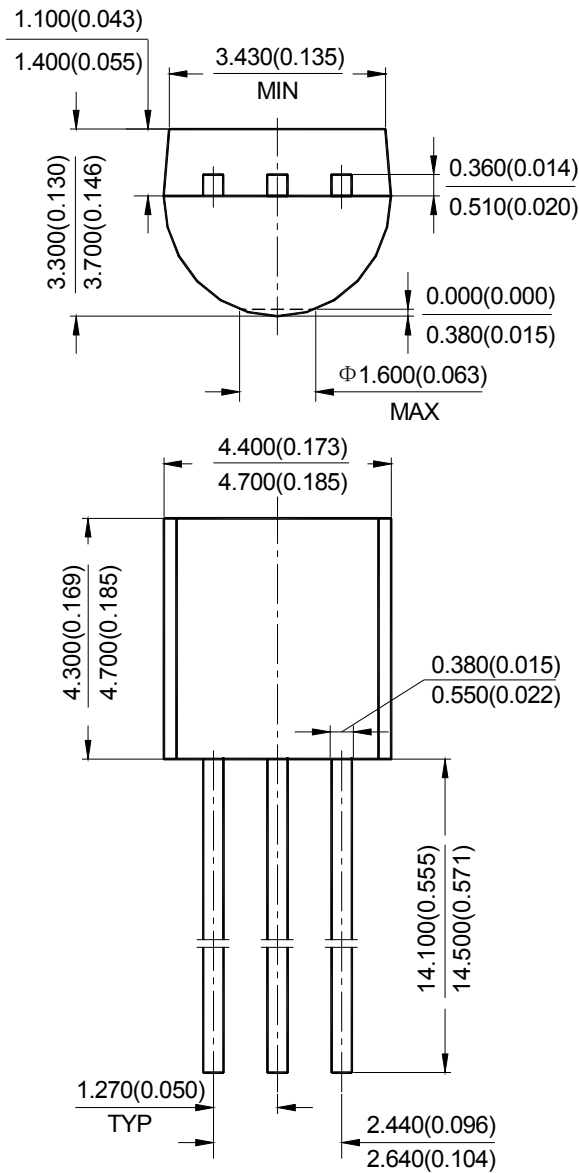



**Mechanical Dimensions (Continued)**

**TO-92 ( Ammo Packing)**

**Unit: mm(inch)**

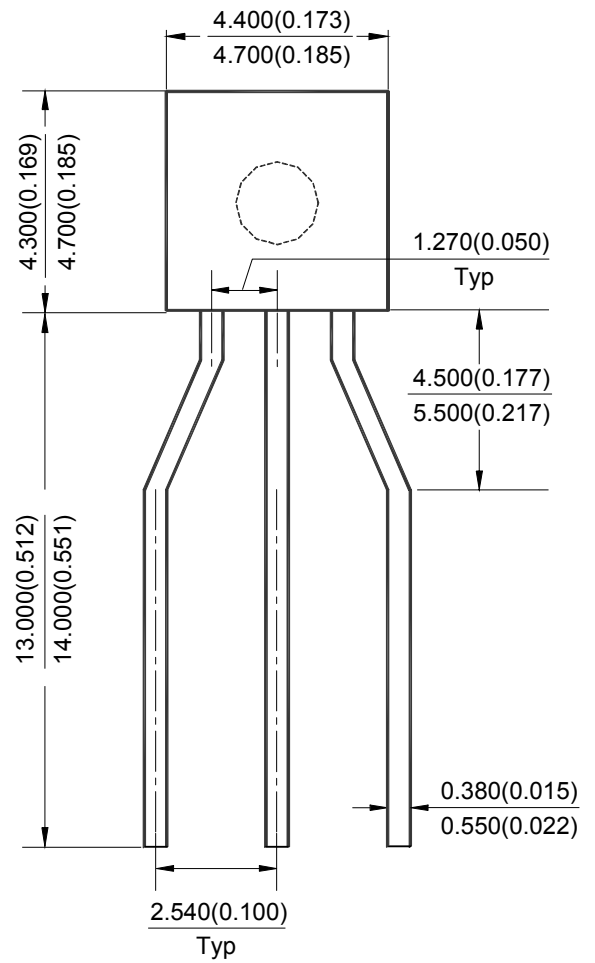
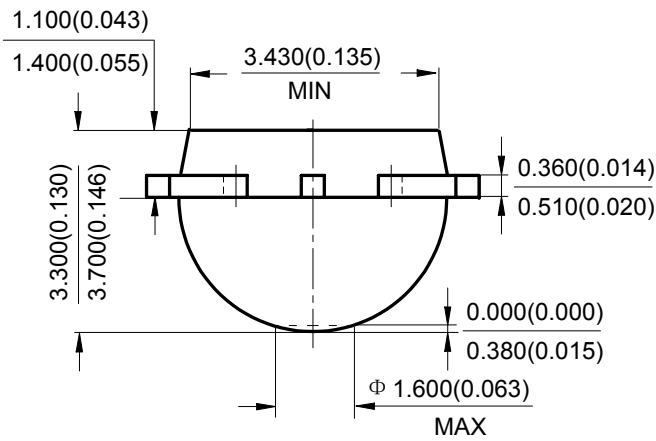



**Mechanical Dimensions (Continued)**

**TO-18**

**Unit: mm(inch)**

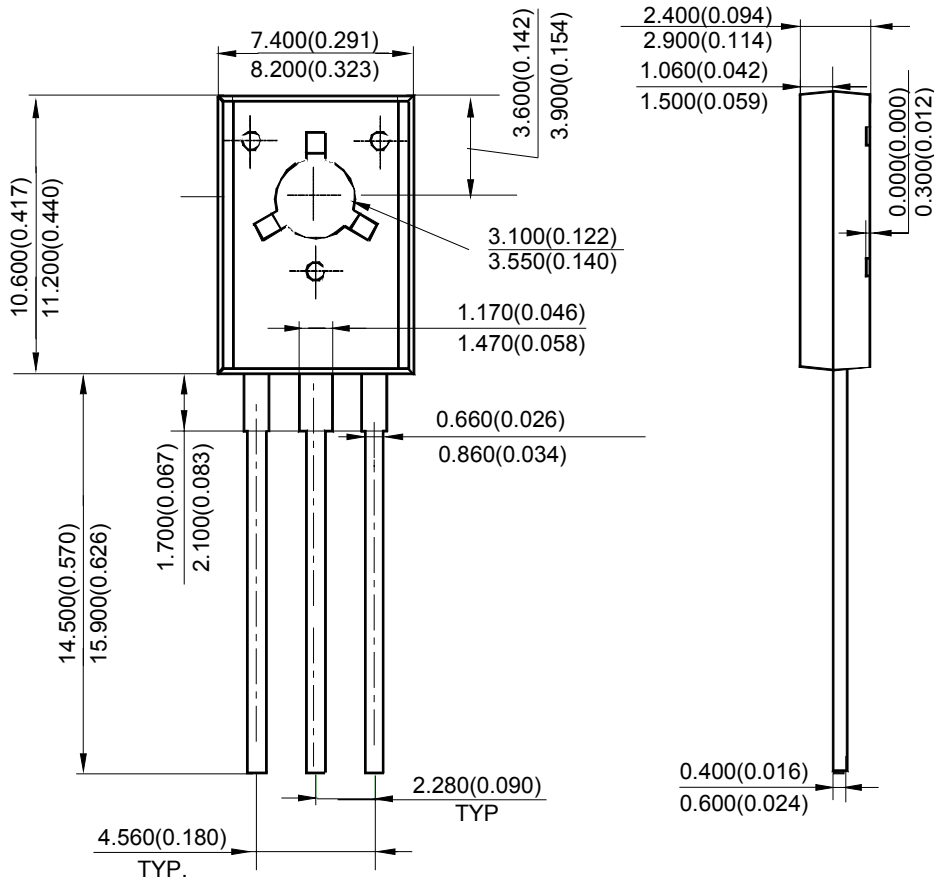



## BCD Semiconductor Manufacturing Limited

<http://www.bcdsemi.com>

### IMPORTANT NOTICE

BCD Semiconductor Manufacturing Limited reserves the right to make changes without further notice to any products or specifications herein. BCD Semiconductor Manufacturing Limited does not assume any responsibility for use of any its products for any particular purpose, nor does BCD Semiconductor Manufacturing Limited assume any liability arising out of the application or use of any its products or circuits. BCD Semiconductor Manufacturing Limited does not convey any license under its patent rights or other rights nor the rights of others.

---

#### MAIN SITE

##### - Headquarters

##### BCD Semiconductor Manufacturing Limited

No. 1600, Zi Xing Road, Shanghai Zizhu Science-based Industrial Park, 200241, China  
Tel: +86-21-24162266, Fax: +86-21-24162277

##### - Wafer Fab

##### Shanghai SIM-BCD Semiconductor Manufacturing Co., Ltd.

800 Yi Shan Road, Shanghai 200233, China  
Tel: +86-21-6485 1491, Fax: +86-21-5450 0008

#### REGIONAL SALES OFFICE

##### Shenzhen Office

##### Shanghai SIM-BCD Semiconductor Manufacturing Co., Ltd., Shenzhen Office

Unit A Room 1203, Skyworth Bldg., Gaoxin Ave.1.S., Nanshan District, Shenzhen, China  
Tel: +86-755-8826 7951  
Fax: +86-755-8826 7865

##### Taiwan Office

##### BCD Semiconductor (Taiwan) Company Limited

4F, 298-1, Rui Guang Road, Nei-Hu District, Taipei, Taiwan  
Tel: +886-2-2656 2808  
Fax: +886-2-2656 2806

##### USA Office

##### BCD Semiconductor Corp.

30920 Huntwood Ave. Hayward, CA 94544, USA  
Tel : +1-510-324-2988  
Fax: +1-510-324-2788