

**ADJUSTABLE PRECISION SHUNT REGULATORS**

**AZ431-B**

**General Description**

The AZ431-B is a three-terminal adjustable shunt regulator with guaranteed thermal stability over a full operation range. It features sharp turn-on characteristics, low temperature coefficient and low output impedance, which make it ideal substitute for Zener diode in applications such as switching power supply, charger and other adjustable regulators.

The output voltage of AZ431-B can be set to any value between  $V_{REF}$  (2.5V) and the corresponding maximum cathode voltage.

The AZ431-B precision reference is offered in two voltage tolerance: 0.4% and 0.8%.

This IC is available in 4 packages: TO-92 (bulk or ammo packing), SOT-23, SOT-23-5 and SOT-89.

**Features**

- Programmable Precise Output Voltage from 2.5V to 18V
- High Stability under Capacitive Load
- Low Temperature Deviation: 4.5mV Typical
- Low Equivalent Full-range Temperature Coefficient with 20PPM/°C Typical
- Sink Current Capacity from 1mA to 100mA
- Low Output Noise
- Wide Operating Range of -40 to 125°C

**Applications**

- Charger
- Voltage Adapter
- Switching Power Supply
- Graphic Card
- Precision Voltage Reference

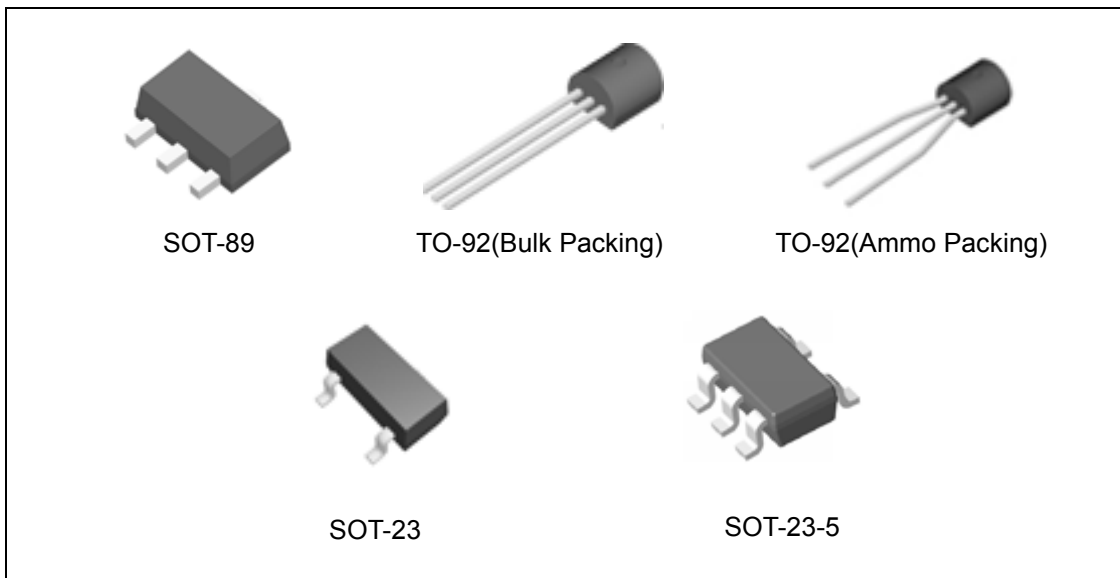

Figure 1. Package Types of AZ431-B

**ADJUSTABLE PRECISION SHUNT REGULATORS**

**AZ431-B**

**Pin Configuration**

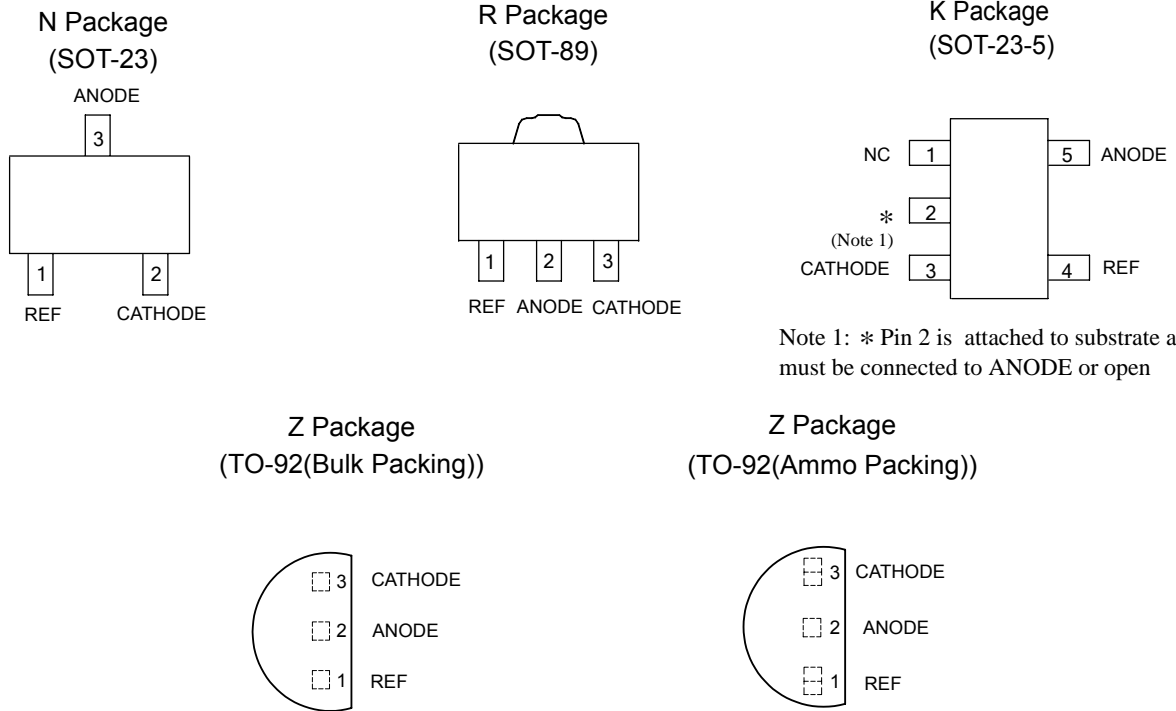

Figure 2. Pin Configuration of AZ431-B (Top View)

**Functional Block Diagram**

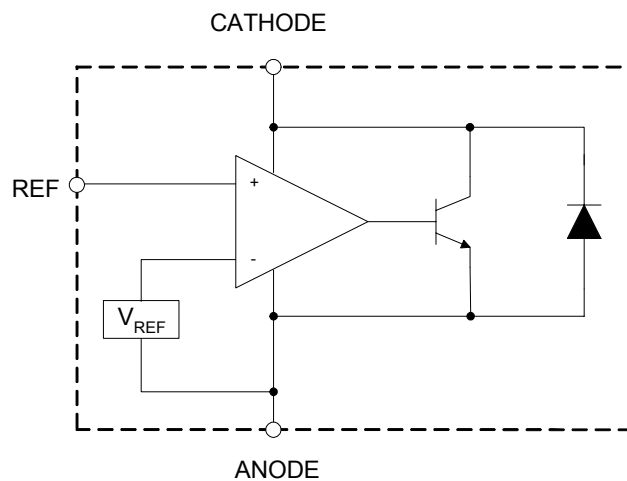

Figure 3. Functional Block Diagram of AZ431-B



**ADJUSTABLE PRECISION SHUNT REGULATORS**

**AZ431-B**

**Ordering Information**

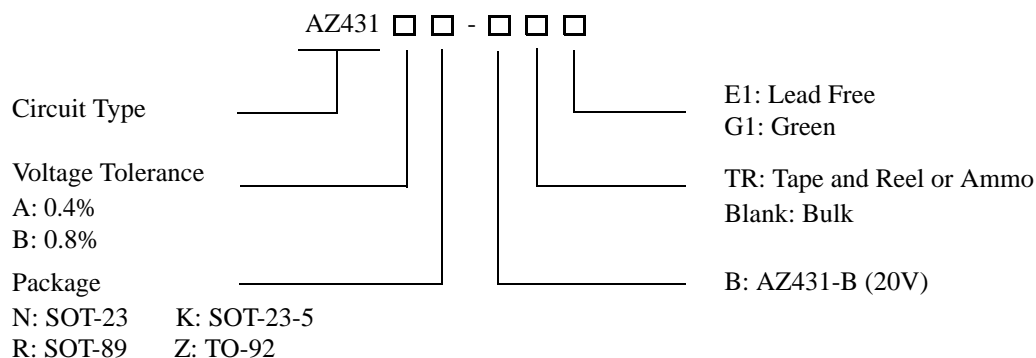

Package	Temperature Range	Voltage Tolerance	Part Number		Marking ID		Packing Type
			Lead Free	Green	Lead Free	Green	
SOT-23	-40 to 125°C	0.4%	AZ431AN-BTRE1	AZ431AN-BTRG1	EA4	GA4	Tape & Reel
		0.8%	AZ431BN-BTRE1	AZ431BN-BTRG1	EA5	GA5	Tape & Reel
SOT-23-5	-40 to 125°C	0.4%	AZ431AK-BTRE1	AZ431AK-BTRG1	E4A	G4A	Tape & Reel
		0.8%	AZ431BK-BTRE1	AZ431BK-BTRG1	E4B	G4B	Tape & Reel
TO-92	-40 to 125°C	0.4%	AZ431AZ-BE1	AZ431AZ-BG1	AZ431AZ-BE1	AZ431AZ-BG1	Bulk
		0.4%	AZ431AZ-BTRE1	AZ431AZ-BTRG1	AZ431AZ-BE1	AZ431AZ-BG1	Ammo
		0.8%	AZ431BZ-BE1	AZ431BZ-BG1	AZ431BZ-BE1	AZ431BZ-BG1	Bulk
		0.8%	AZ431BZ-BTRE1	AZ431BZ-BTRG1	AZ431BZ-BE1	AZ431BZ-BG1	Ammo
SOT-89	-40 to 125°C	0.4%	AZ431AR-BTRE1	AZ431AR-BTRG1	E43C	G43C	Tape & Reel
		0.8%	AZ431BR-BTRE1	AZ431BR-BTRG1	E43D	G43D	Tape & Reel

BCD Semiconductor's Pb-free products, as designated with "E1" suffix in the part number, are RoHS compliant. Products with "G1" suffix are available in green packages.

**ADJUSTABLE PRECISION SHUNT REGULATORS****AZ431-B****Absolute Maximum Ratings (Note 2)**

Parameter	Symbol	Value	Unit
Cathode Voltage	$V_{KA}$	20	V
Cathode Current Range (Continuous)	$I_{KA}$	-100 to 150	mA
Reference Input Current Range	$I_{REF}$	10	mA
Power Dissipation	$P_D$	Z, R Package: 770	mW
		N, K Package: 370	
Junction Temperature	$T_J$	150	°C
Storage Temperature Range	$T_{STG}$	-65 to 150	°C
ESD (Human Body Model)	ESD	2000	V

Note 2: Stresses greater than those listed under "Absolute Maximum Ratings" may cause permanent damage to the device. These are stress ratings only, and functional operation of the device at these or any other conditions beyond those indicated under "Recommended Operating Conditions" is not implied. Exposure to "Absolute Maximum Ratings" for extended periods may affect device reliability.

**Recommended Operating Conditions**

Parameter	Symbol	Min	Max	Unit
Cathode Voltage	$V_{KA}$	$V_{REF}$	18	V
Cathode Current	$I_{KA}$	1.0	100	mA
Operating Ambient Temperature Range	$T_A$	-40	125	°C



**ADJUSTABLE PRECISION SHUNT REGULATORS**

**AZ431-B**

**Electrical Characteristics**

Operating Conditions:  $T_A=25^{\circ}\text{C}$ , unless otherwise specified.

Parameter	Test Circuit	Symbol	Conditions	Min	Typ	Max	Unit	
Reference Voltage	0.4%	4	$V_{\text{REF}}$	$V_{\text{KA}}=V_{\text{REF}}, I_{\text{KA}}=10\text{mA}$	2.490	2.500	2.510	V
	0.8%				2.480	2.500	2.520	
Deviation of Reference Voltage Over Full Temperature Range	4	$\Delta V_{\text{REF}}$	$V_{\text{KA}}=V_{\text{REF}}$ $I_{\text{KA}}=10\text{mA}$	0 to $70^{\circ}\text{C}$	4.5	8	mV	
				-40 to $85^{\circ}\text{C}$	4.5	10		
				-40 to $125^{\circ}\text{C}$	4.5	16		
Ratio of Change in Reference Voltage to the Change in Cathode Voltage	5	$\frac{\Delta V_{\text{REF}}}{\Delta V_{\text{KA}}}$	$I_{\text{KA}}=10\text{mA}$	$\Delta V_{\text{KA}}=10\text{V to }V_{\text{REF}}$	-1.0	-2.7	mV/V	
				$\Delta V_{\text{KA}}=18\text{V to }10\text{V}$	-0.5	-2.0		
Reference Current	5	$I_{\text{REF}}$	$I_{\text{KA}}=10\text{mA}, R1=10\text{K}\Omega, R2=\infty$		0.7	4	$\mu\text{A}$	
Deviation of Reference Current Over Full Temperature Range	5	$\Delta I_{\text{REF}}$	$I_{\text{KA}}=10\text{mA}, R1=10\text{K}\Omega, R2=\infty$ $T_A=-40$ to $125^{\circ}\text{C}$		0.4	1.2	$\mu\text{A}$	
Minimum Cathode Current for Regulation	4	$I_{\text{KA}}(\text{Min})$	$V_{\text{KA}}=V_{\text{REF}}$		0.4	1.0	mA	
Off-state Cathode Current	6	$I_{\text{KA}}(\text{Off})$	$V_{\text{KA}}=18\text{V}, V_{\text{REF}}=0$		0.05	1.0	$\mu\text{A}$	
Dynamic Impedance	4	$Z_{\text{KA}}$	$V_{\text{KA}}=V_{\text{REF}}, I_{\text{KA}}=1$ to $100\text{mA}$ $f \leq 1.0\text{KHz}$		0.2	0.5	$\Omega$	
Thermal Resistance		$\theta_{\text{JC}}$	SOT-23		177.65		$^{\circ}\text{C/W}$	
			SOT-23-5		177.65			
			TO-92		107.04			
			SOT-89		111.03			

**Electrical Characteristics (Continued)**

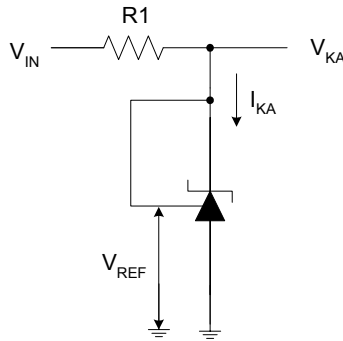

Figure 4. Test Circuit 4 for  $V_{KA} = V_{REF}$

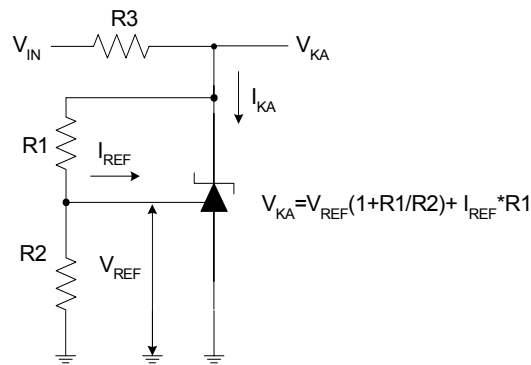

Figure 5. Test Circuit 5 for  $V_{KA} > V_{REF}$

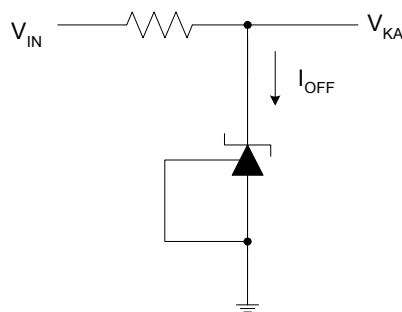

Figure 6. Test Circuit 6 for  $I_{OFF}$



**ADJUSTABLE PRECISION SHUNT REGULATORS**

**AZ431-B**

**Typical Performance Characteristics**

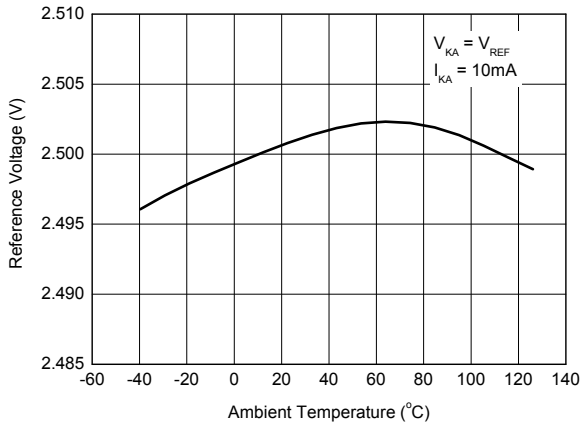

Figure 7. Reference Voltage vs. Ambient Temperature

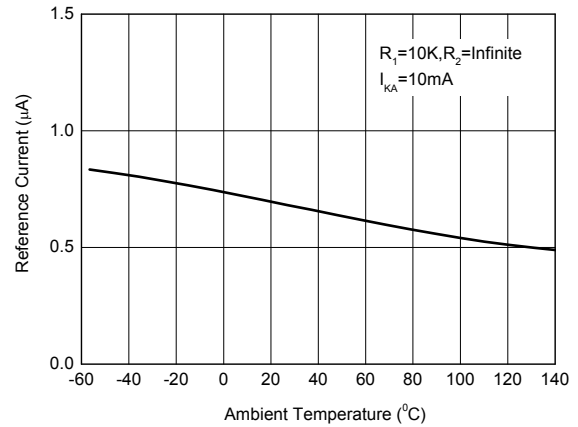

Figure 8. Reference Current vs. Ambient Temperature

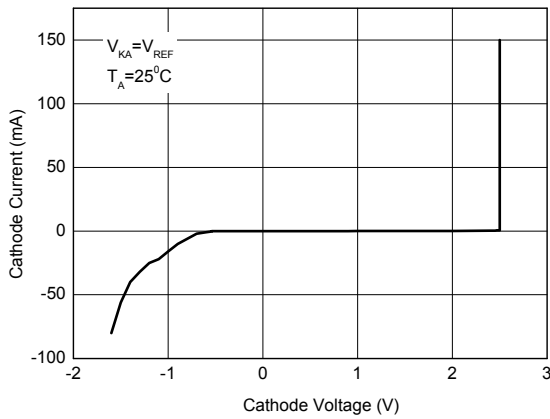

Figure 9. Cathode Current vs. Cathode Voltage

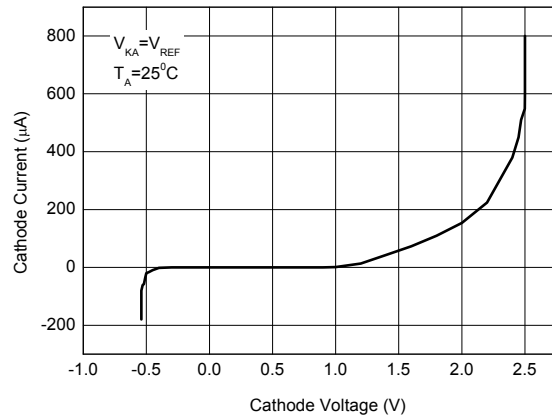

Figure 10. Cathode Current vs. Cathode Voltage



**ADJUSTABLE PRECISION SHUNT REGULATORS**

**AZ431-B**

**Typical Performance Characteristics (Continued)**

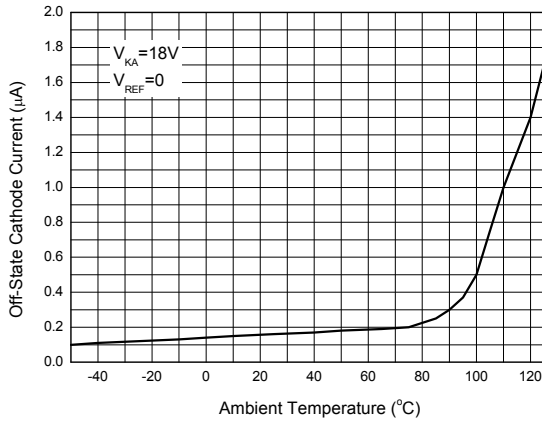

Figure 11. Off-State Cathode Current vs. Ambient Temperature

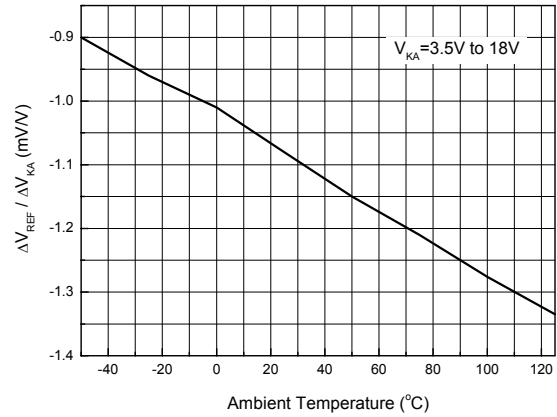

Figure 12. Ratio of Delta Reference Voltage to the Ratio of Delta Cathode Voltage

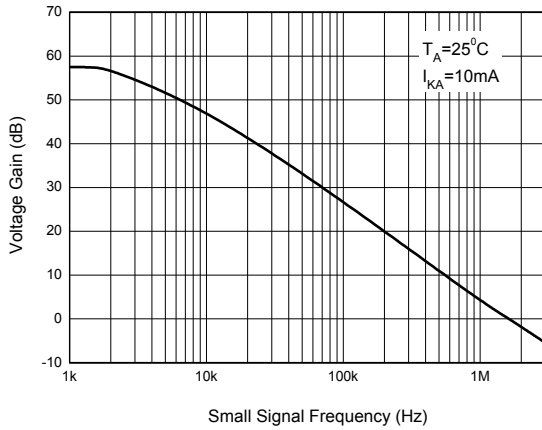
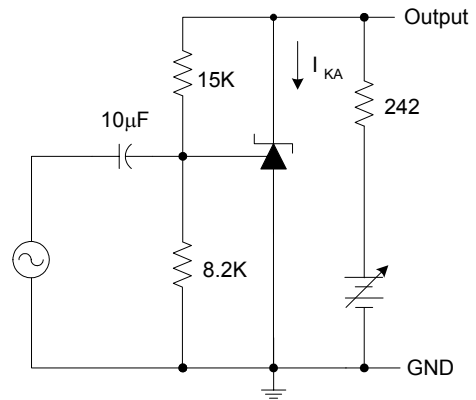

Figure 13. Small Signal Voltage Gain vs. Frequency



**ADJUSTABLE PRECISION SHUNT REGULATORS**

**AZ431-B**

**Typical Performance Characteristics (Continued)**

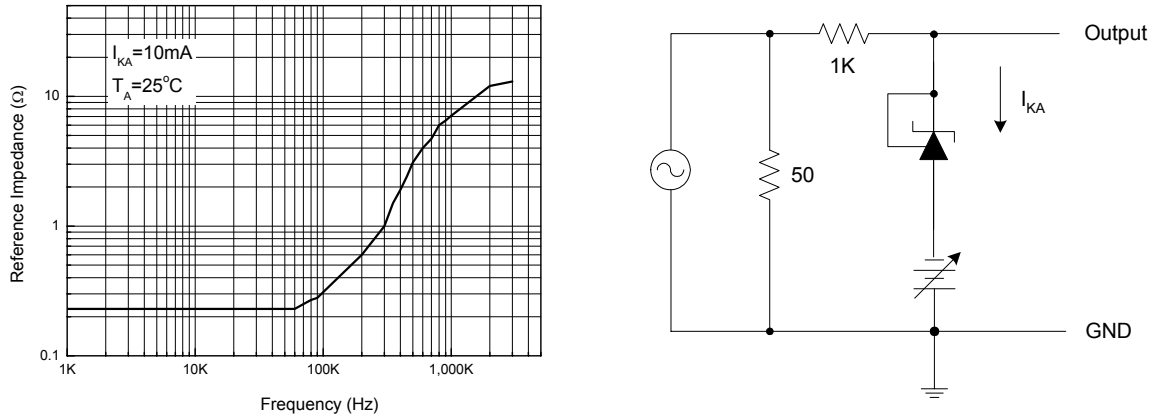

Figure 15. Reference Impedance vs. Frequency

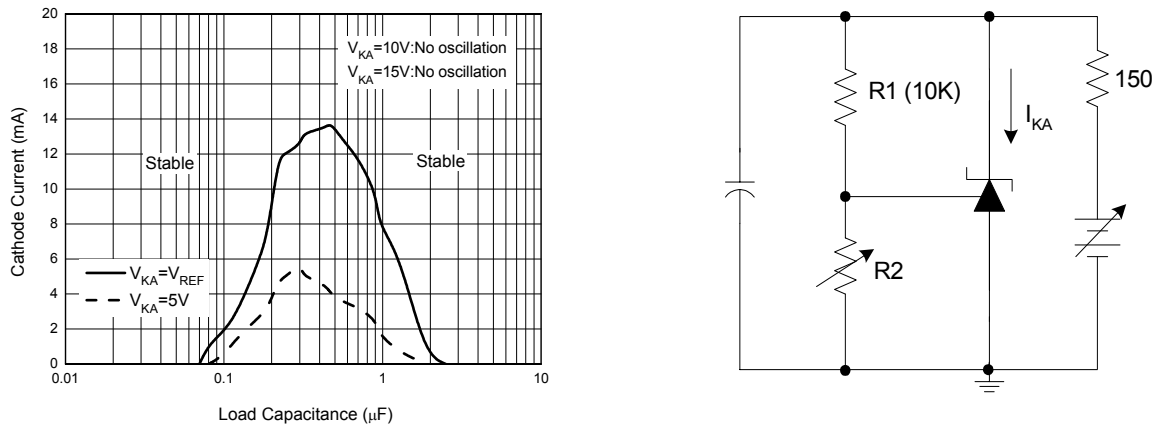

Figure 16. Stability Boundary Conditions vs. Load Capacitance

**Typical Performance Characteristics (Continued)**

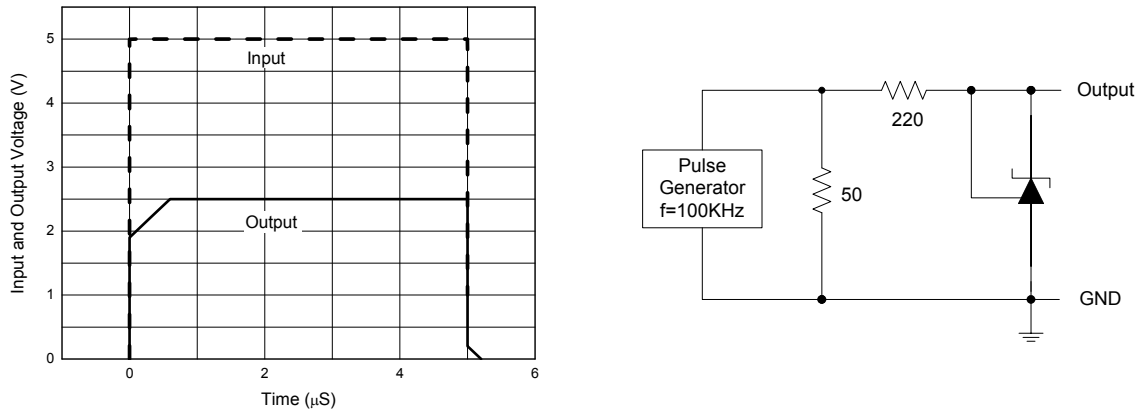

Figure 18. Pulse Response of Input and Output Voltage

**Typical Application**

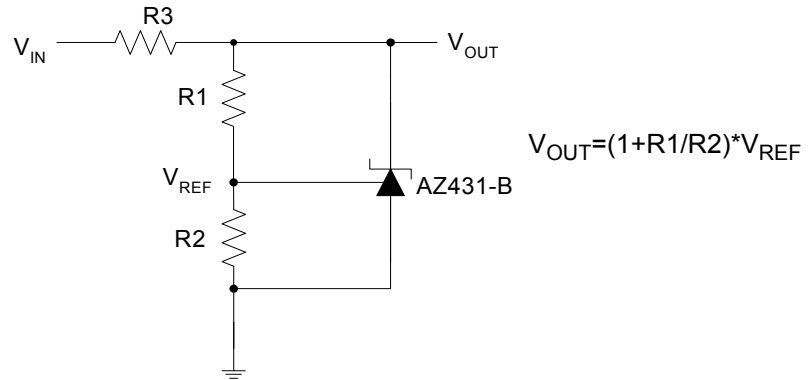

Figure 19. Shunt Regulator

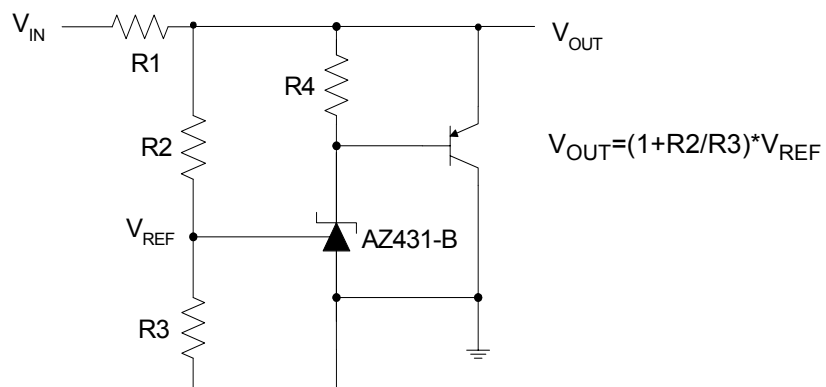

Figure 20. High Current Shunt Regulator

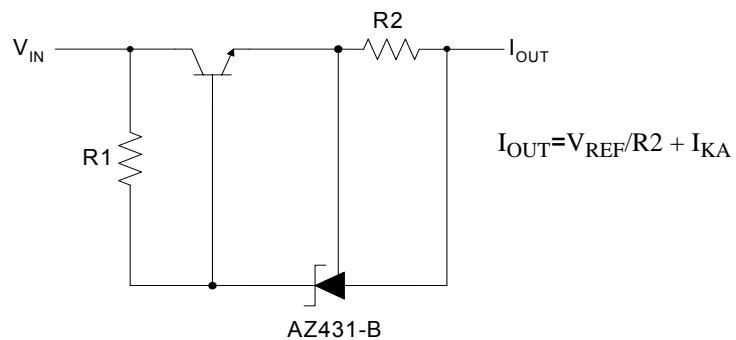

Figure 21. Current Source or Current Limit

Typical Application (Continued)

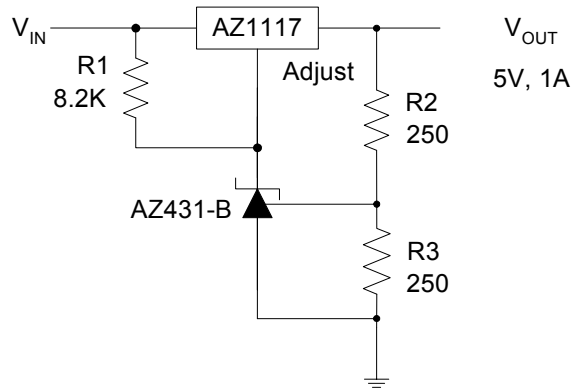

Figure 22. Precision 5V 1A Regulator

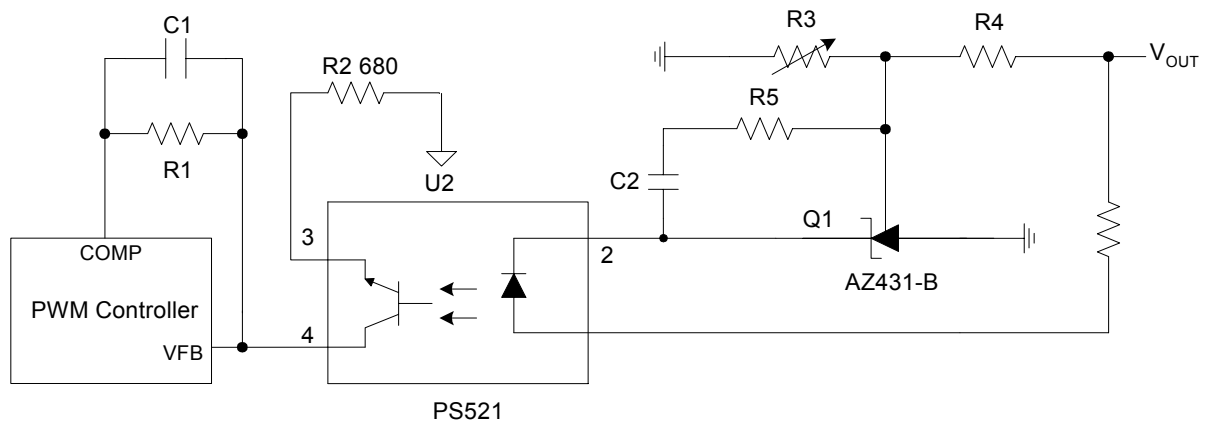

Figure 23. PWM Converter with Reference



**ADJUSTABLE PRECISION SHUNT REGULATORS**

**AZ431-B**

**Mechanical Dimensions**

**TO-92(Bulk Packing)**

**Unit: mm(inch)**

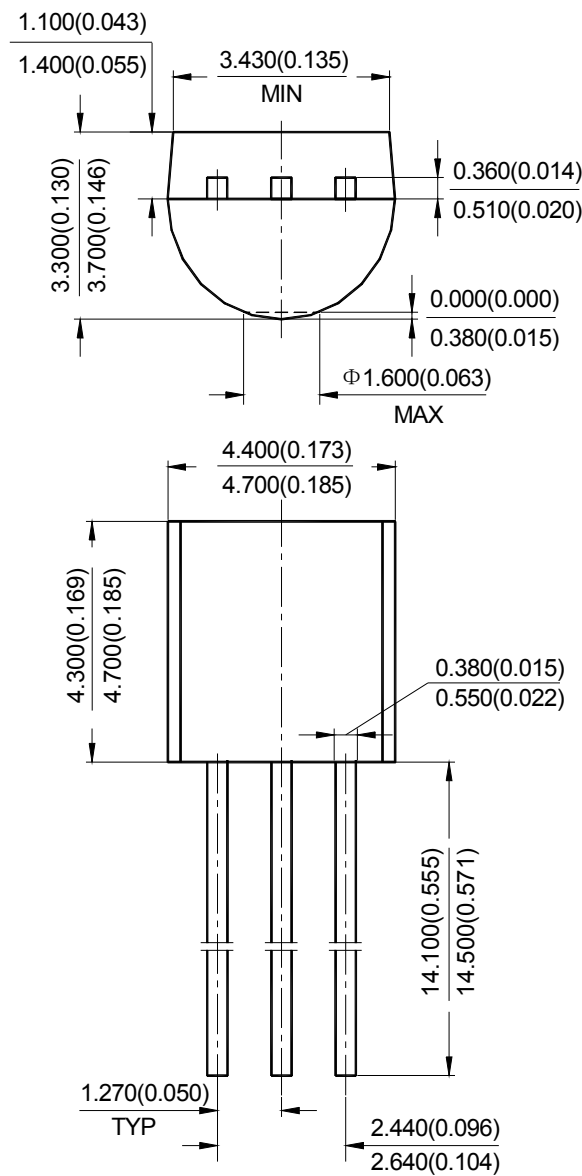



**ADJUSTABLE PRECISION SHUNT REGULATORS**

**AZ431-B**

**Mechanical Dimensions (Continued)**

**TO-92(Ammo Packing)**

**Unit: mm(inch)**

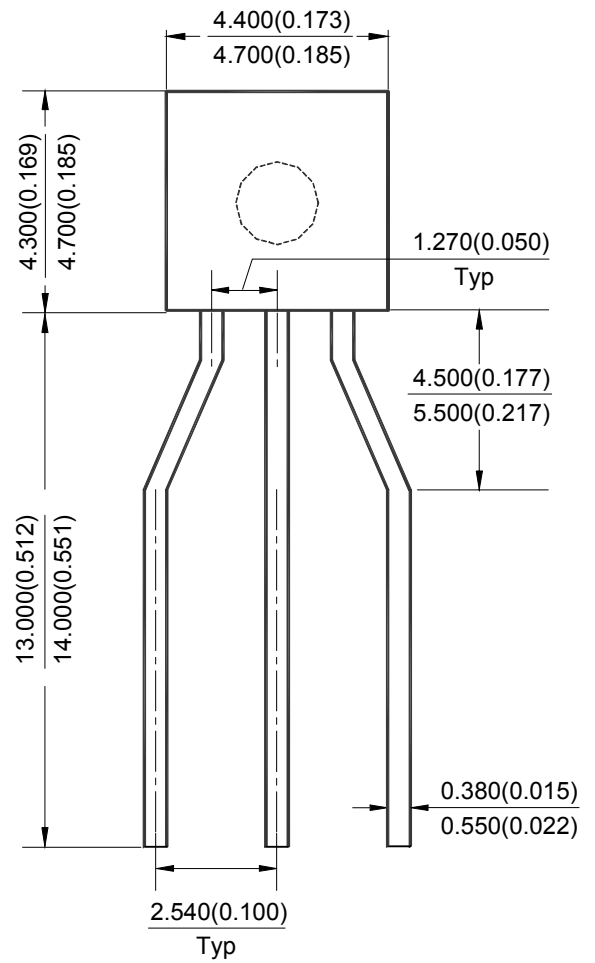
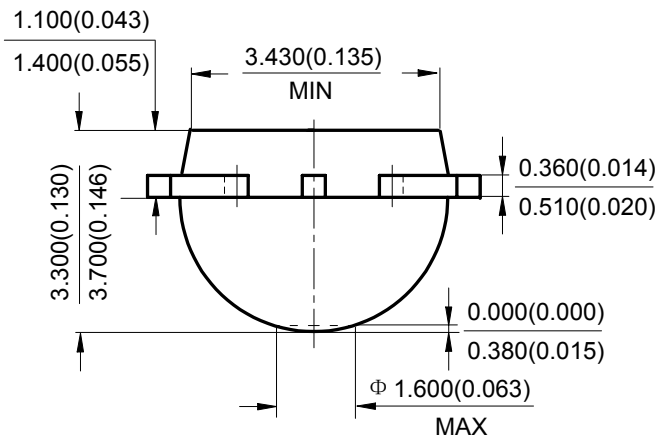



**ADJUSTABLE PRECISION SHUNT REGULATORS**

**AZ431-B**

**Mechanical Dimensions (Continued)**

**SOT-23**

**Unit: mm(inch)**

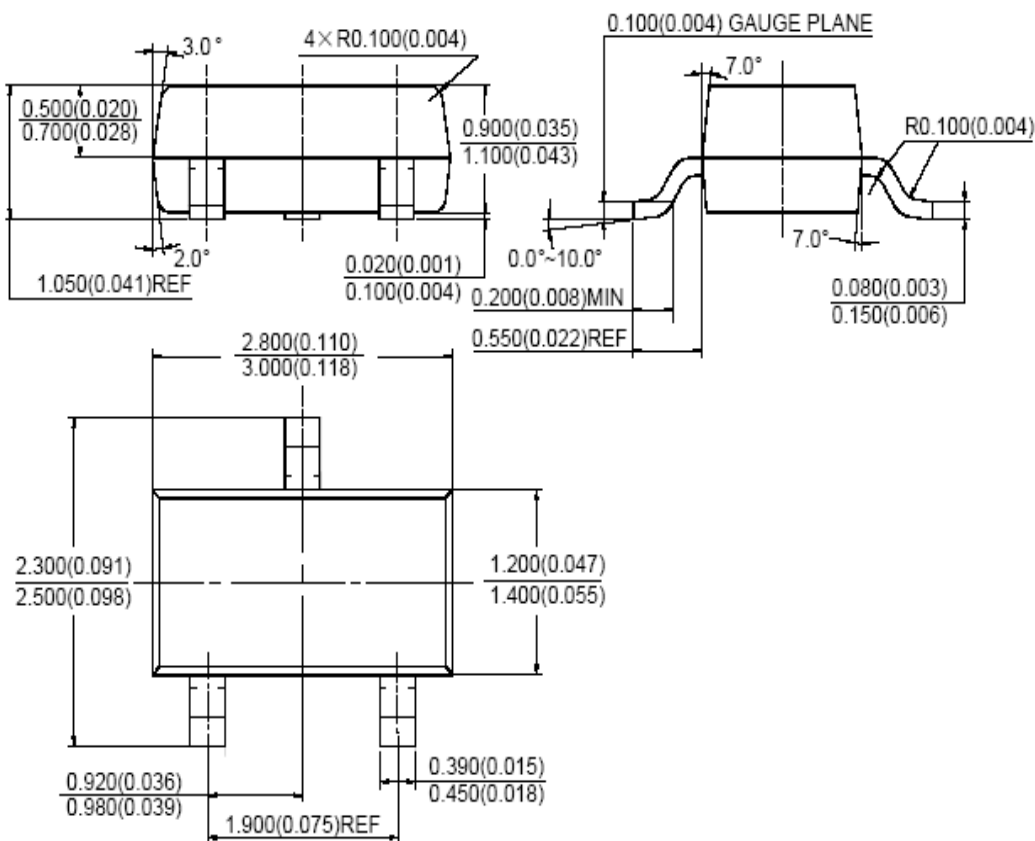



**ADJUSTABLE PRECISION SHUNT REGULATORS**

**AZ431-B**

**Mechanical Dimensions (Continued)**

**SOT-23-5**

**Unit: mm(inch)**

