

### General Description

The AZ494A/C is a voltage mode pulse width modulation switching regulator control circuit designed primarily for power supply control.

The AZ494A/C consists of a reference voltage circuit, two error amplifiers, an on-chip adjustable oscillator, a dead-time control (DTC) comparator, a pulse-steering control flip-flop, and an output control circuit. The precision of voltage reference ( $V_{REF}$ ) is improved up to  $\pm 1\%$  through trimming and this provides a better output voltage regulation. The AZ494A/C provides for push-pull or single-ended output operation, which can be selected through the output control.

The difference between AZ494A and AZ494C is that they have 4.95V and 5V reference voltage respectively.

The AZ494A/C is available in standard packages of DIP-16 and SOIC-16.

### Features

- Stable 4.95V/5V Reference Voltage Trimmed to  $\pm 1.0\%$  Accuracy
- Uncommitted Output TR for 200mA Sink or Source Current
- Single-End or Push-Pull Operation Selected by Output Control
- Internal Circuitry Prohibits Double Pulse at Either Output
- Complete PWM Control Circuit with Variable Duty Cycle
- On-Chip Oscillator with Master or Slave Operation

### Applications

- SMPS
- Back Light Inverter
- Charger

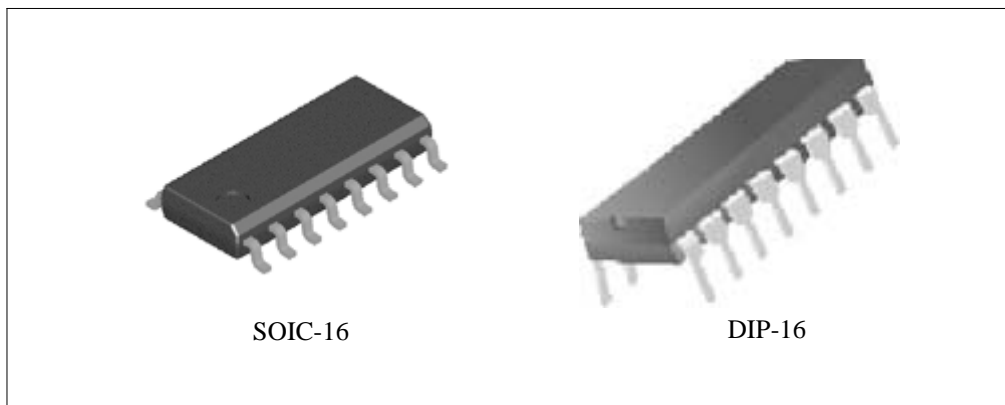

Figure 1. Package Types of AZ494A/C

**Pin Configuration**

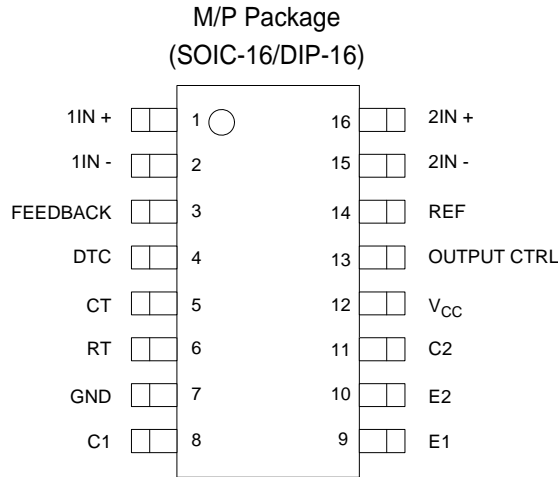

Figure 2. Pin Configuration of AZ494A/C (Top View)

**Output Function Control Table**

Signal for Output Control	Output Function
$V_I = GND$	Single-ended or parallel output
$V_I = V_{REF}$	Normal push-pull operation

**Functional Block Diagram**

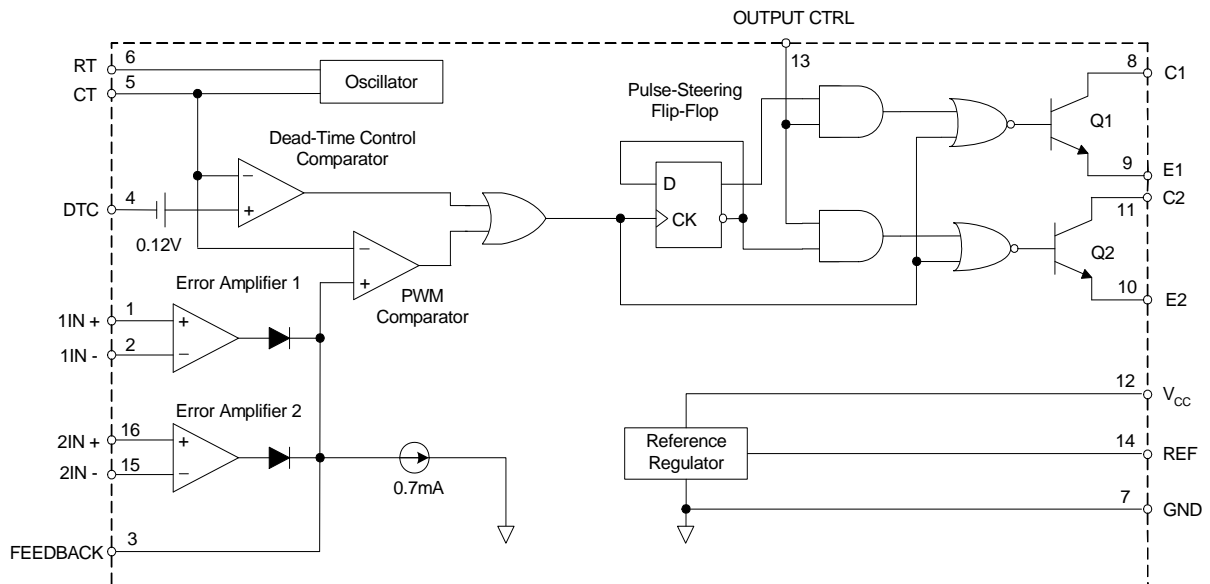

Figure 3. Functional Block Diagram of AZ494A/C



**PULSE-WIDTH-MODULATION CONTROL CIRCUITS**

**AZ494A/C**

**Ordering Information**

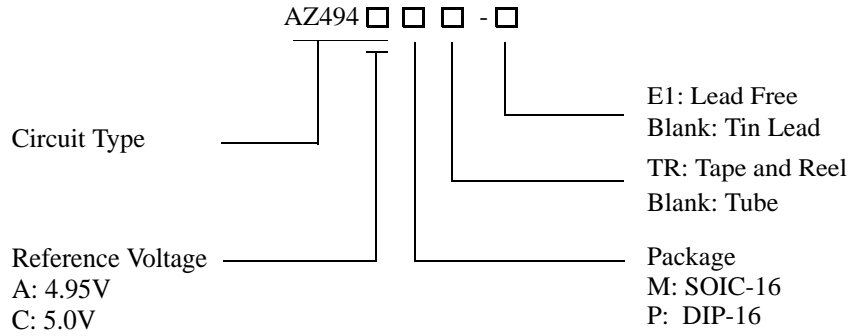

Package	Temperature Range	Part Number		Marking ID		Packing Type
		Tin Lead	Lead Free	Tin Lead	Lead Free	
SOIC-16	-40 to 85°C	AZ494AM	AZ494AM-E1	AZ494AM	AZ494AM-E1	Tube
		AZ494AMTR	AZ494AMTR-E1	AZ494AM	AZ494AM-E1	Tape & Reel
		AZ494CM	AZ494CM-E1	AZ494CM	AZ494CM-E1	Tube
		AZ494CMTR	AZ494CMTR-E1	AZ494CM	AZ494CM-E1	Tape & Reel
DIP-16		AZ494AP	AZ494AP-E1	AZ494AP	AZ494AP-E1	Tube
		AZ494CP	AZ494CP-E1	AZ494CP	AZ494CP-E1	Tube

BCD Semiconductor's Pb-free products, as designated with "E1" suffix in the part number, are RoHS compliant.

**PULSE-WIDTH-MODULATION CONTROL CIRCUITS****AZ494A/C****Absolute Maximum Ratings (Note 1)**

Parameter	Symbol	Value	Unit
Supply Voltage (Note 2)	$V_{CC}$	40	V
Amplifier Input Voltage	$V_I$	-0.3 to $V_{CC} + 0.3$	V
Collector Output Voltage	$V_O$	40	V
Collector Output Current	$I_O$	250	mA
Package Thermal Impedance (Note 3)	$R_{\theta JA}$	M Package	73
		P Package	67
Lead Temperature 1.6mm from case for 10 seconds		260	°C
Storage Temperature Range	$T_{STG}$	-65 to 150	°C
ESD rating (Machine Model)		200	V

Note 1: Stresses greater than those listed under "Absolute Maximum Ratings" may cause permanent damage to the device. These are stress ratings only, and functional operation of the device at these or any other conditions beyond those indicated under "Recommended Operating Conditions" is not implied. Exposure to "Absolute Maximum Ratings" for extended periods may affect device reliability.

Note 2: All voltage values are with respect to the network ground terminal.

Note 3: Maximum power dissipation is a function of  $T_J(\max)$ ,  $R_{\theta JA}$  and  $T_A$ . The maximum allowable power dissipation at any allowable ambient temperature is  $P_D = (T_J(\max) - T_A) / R_{\theta JA}$ . Operating at the absolute maximum  $T_J$  of 150°C can affect reliability.

**Recommended Operating Conditions**

Parameter	Symbol	Min	Typ	Max	Unit
Supply Voltage	$V_{CC}$	7	15	36	V
Collector Output Voltage	$V_{C1}, V_{C2}$		30	36	V
Collector Output Current (Each Transistor)	$I_{C1}, I_{C2}$			200	mA
Amplifier Input Voltage	$V_I$	0.3		$V_{CC} - 2$	V
Current Into Feedback Terminal	$I_{FB}$			0.3	mA
Reference Output Current	$I_{REF}$			10	mA
Timing Capacitor	$C_T$	0.00047	0.001	10	μF
Timing Resistor	$R_T$	1.8	30	500	KΩ
Oscillator Frequency	$f_{osc}$	1.0	40	200	KHz
PWM Input Voltage (Pin 3, 4, 14)		0.3		5.3	V
Operating Free-Air Temperature	$T_A$	-40		85	°C



**PULSE-WIDTH-MODULATION CONTROL CIRCUITS**

**AZ494A/C**

**Electrical Characteristics**

$T_A = 25^{\circ}\text{C}$ ,  $V_{CC}=20\text{V}$ ,  $f=10\text{KHz}$  unless otherwise noted.

Parameter	Symbol	Conditions	Min	Typ	Max	Unit
<b>Reference Section</b>						
Output Reference Voltage for AZ494A	$V_{REF}$	$I_{REF}=1\text{mA}$	4.90	4.95	5.0	V
		$I_{REF}=1\text{mA}$ , $T_A = -40$ to $85^{\circ}\text{C}$	4.85	4.95	5.05	V
Output Reference Voltage for AZ494C	$V_{REF}$	$I_{REF}=1\text{mA}$	4.95	5.0	5.05	V
		$I_{REF}=1\text{mA}$ , $T_A = -40$ to $85^{\circ}\text{C}$	4.9	5.0	5.1	V
Line Regulation	$R_{LINE}$	$V_{CC} = 7\text{V}$ to $36\text{V}$		2	25	mV
Load Regulation	$R_{LOAD}$	$I_{REF}=1\text{mA}$ to $10\text{mA}$		1	15	mV
Short-Circuit Output Current	$I_{SC}$	$V_{REF} = 0\text{V}$	10	35	50	mA
<b>Oscillator Section</b>						
Oscillator Frequency	$f_{OSC}$	$C_T=0.001\mu\text{F}$ , $R_T=30\text{K}\Omega$		40		KHz
		$C_T=0.01\mu\text{F}$ , $R_T=12\text{K}\Omega$	9.2	10	10.8	
		$C_T=0.01\mu\text{F}$ , $R_T=12\text{K}\Omega$ , $T_A = -40$ to $85^{\circ}\text{C}$	9.0		12	
Frequency Change with Temperature	$\Delta f / \Delta T$	$C_T=0.01\mu\text{F}$ , $R_T=12\text{K}\Omega$ , $T_A = -40$ to $85^{\circ}\text{C}$			1	%
<b>Dead-Time Control Section</b>						
Input Bias Current	$I_{BIAS}$	$V_{CC}=15\text{V}$ , $V_4= 0$ to $5.25\text{V}$		-2	-10	$\mu\text{A}$
Maximum Duty Cycle	D(MAX)	$V_{CC}=15\text{V}$ , $V_4= 0\text{V}$ , $\text{Pin } 13= V_{REF}$	45			%
Input Threshold Voltage	$V_{ITH}$	Zero Duty Cycle		3	3.3	V
		Maximum Duty Cycle	0			
<b>Error-Amplifier Section</b>						
Input Offset Voltage	$V_{IO}$	$V_3 = 2.5\text{V}$		2	10	mV
Input Offset Current	$I_{IO}$	$V_3 = 2.5\text{V}$		25	250	nA
Input Bias Current	$I_{BIAS}$	$V_3 = 2.5\text{V}$		0.2	1	$\mu\text{A}$
Common-Mode Input Voltage Range	$V_{CM}$	$V_{CC}=7\text{V}$ to $36\text{V}$	-0.3		$V_{CC}-2$	V
Open-Loop Voltage Gain	$G_{VO}$	$V_O = 0.5\text{V}$ to $3.5\text{V}$	70	95		dB
Unity-Gain Bandwidth	BW			650		KHz
Common-Mode Rejection Ratio	CMRR		65	80		dB
Output Sink Current (Feedback)	$I_{SINK}$	$V_{ID} = -15\text{mV}$ to $-5\text{V}$ , $V_3 = 0.7\text{V}$	-0.3	-0.7		mA
Output Source Current (Feedback)	$I_{SOURCE}$	$V_{ID}=15\text{mV}$ to $5\text{V}$ $V_3 = 3.5\text{V}$	2			mA



**PULSE-WIDTH-MODULATION CONTROL CIRCUITS**

**AZ494A/C**

**Electrical Characteristics (Continued)**

Parameter	Symbol	Conditions	Min	Typ	Max	Unit
<b>PWM Comparator Section</b>						
Input Threshold Voltage	$V_{ITH}$	Zero duty cycle		4	4.5	V
Input Sink Current	$I_{SINK}$	$V_3 = 0.7V$	-0.3	-0.7		mA
<b>Output Section</b>						
Output Saturation Voltage	Common Emitter	$V_{CE(SAT)}$ $V_E = 0V, I_C = 200mA$		1.1	1.3	V
	Emitter Follower	$V_{CC(SAT)}$ $V_{CC} = 15V, I_E = -200mA$		1.5	2.5	
Collector Off-State Current	$I_C(OFF)$	$V_{CE} = 36V, V_{CC} = 36V$		2	100	$\mu A$
Emitter Off-State Current	$I_E(OFF)$	$V_{CC} = V_C = 36V, V_E = 0$			-100	$\mu A$
<b>Total Device</b>						
Supply Current	$I_{CC}$	Pin 6 = $V_{REF}$ , $V_{CC} = 15V$		6	10	mA
<b>Output Switching Characteristics</b>						
Rise Time	$t_R$	Common Emitter Common Collector		100	200	ns
Fall Time	$t_F$	Common Emitter Common Collector		25	100	ns

**Parametr Measurement information**

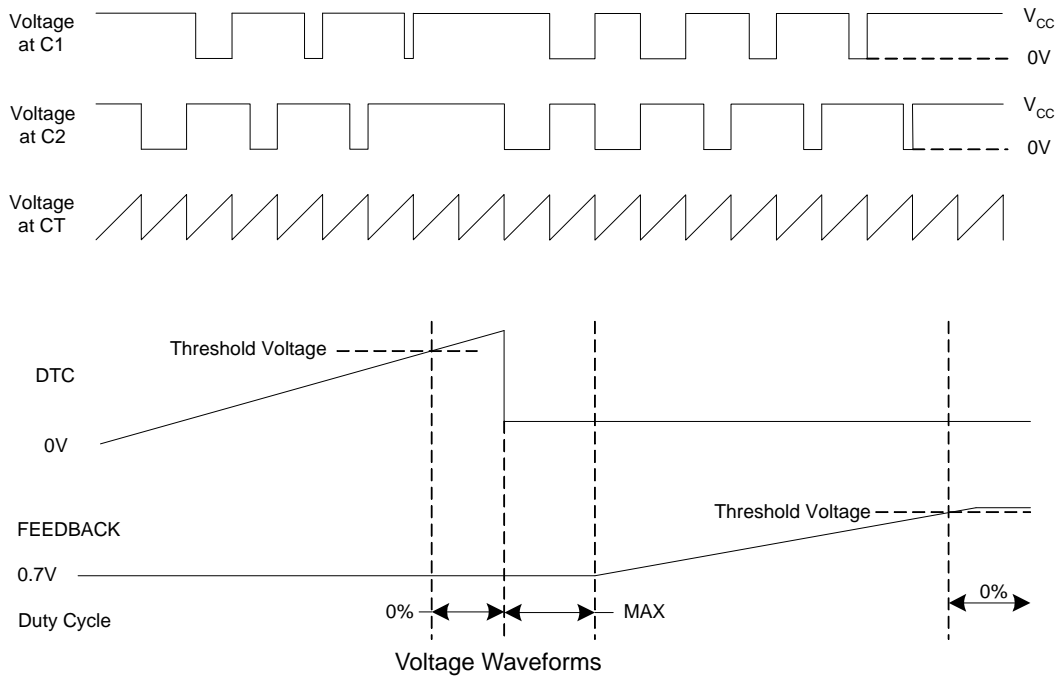
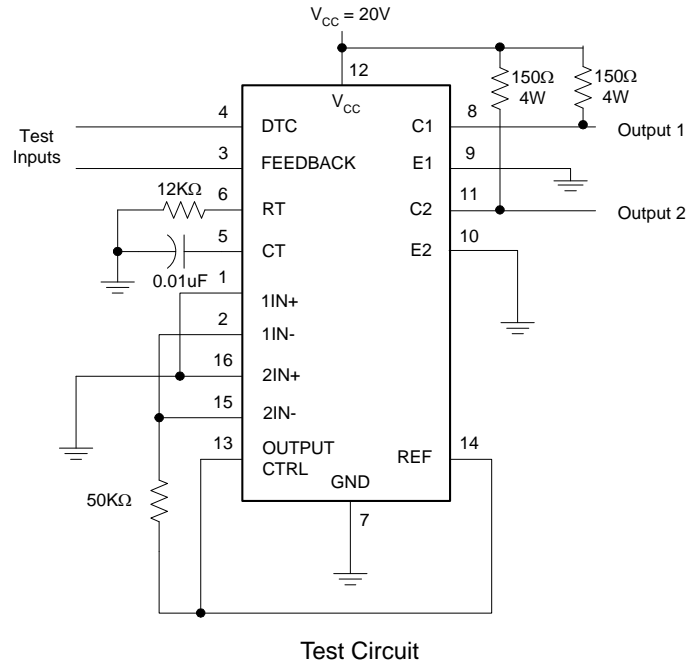

Figure 4. Operational Test Circuit and Waveforms

**Parametr Measurement information (Continued)**

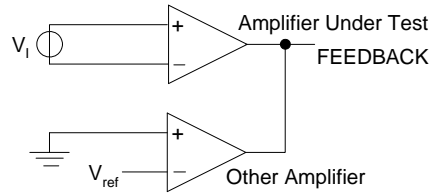
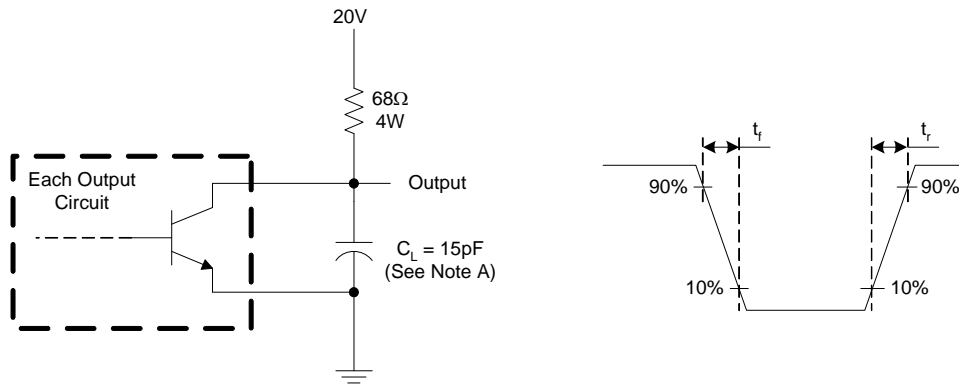
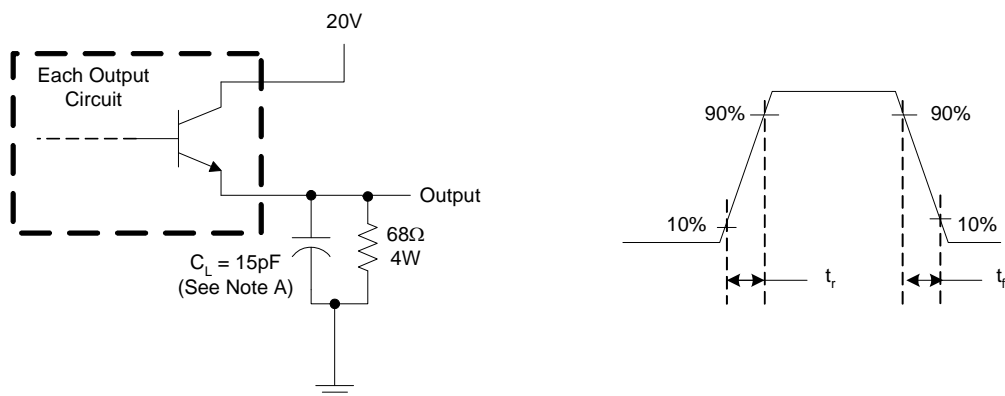

Figure 5. Error Amplifier Characteristics



Note A:  $C_L$  includes probe and jig capacitance.

Figure 6. Common-Emitter Configuration



Note A:  $C_L$  includes probe and jig capacitance.

Figure 7. Emitter-Follower Configuration

**Typical Performance Characteristics**

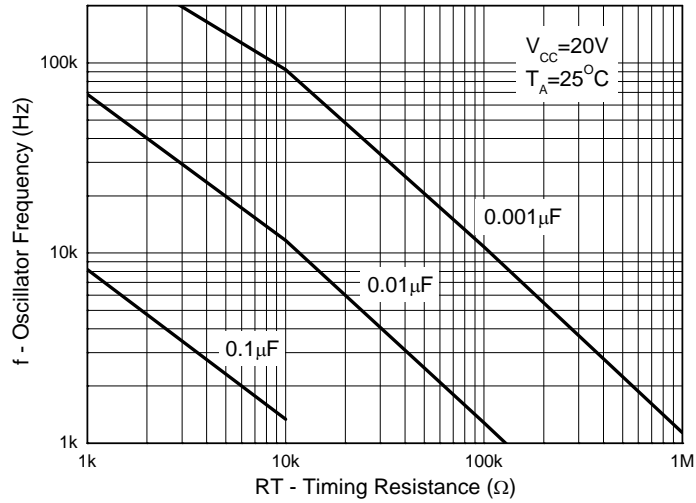

Figure 8. Oscillator Frequency vs. RT and CT

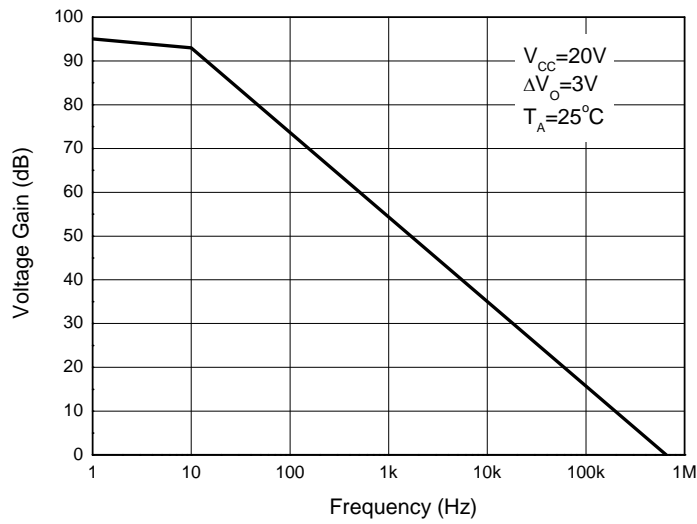

Figure 9. Error Amplifier Small-Signal Voltage Gain vs. Frequency

**Typical Applications**

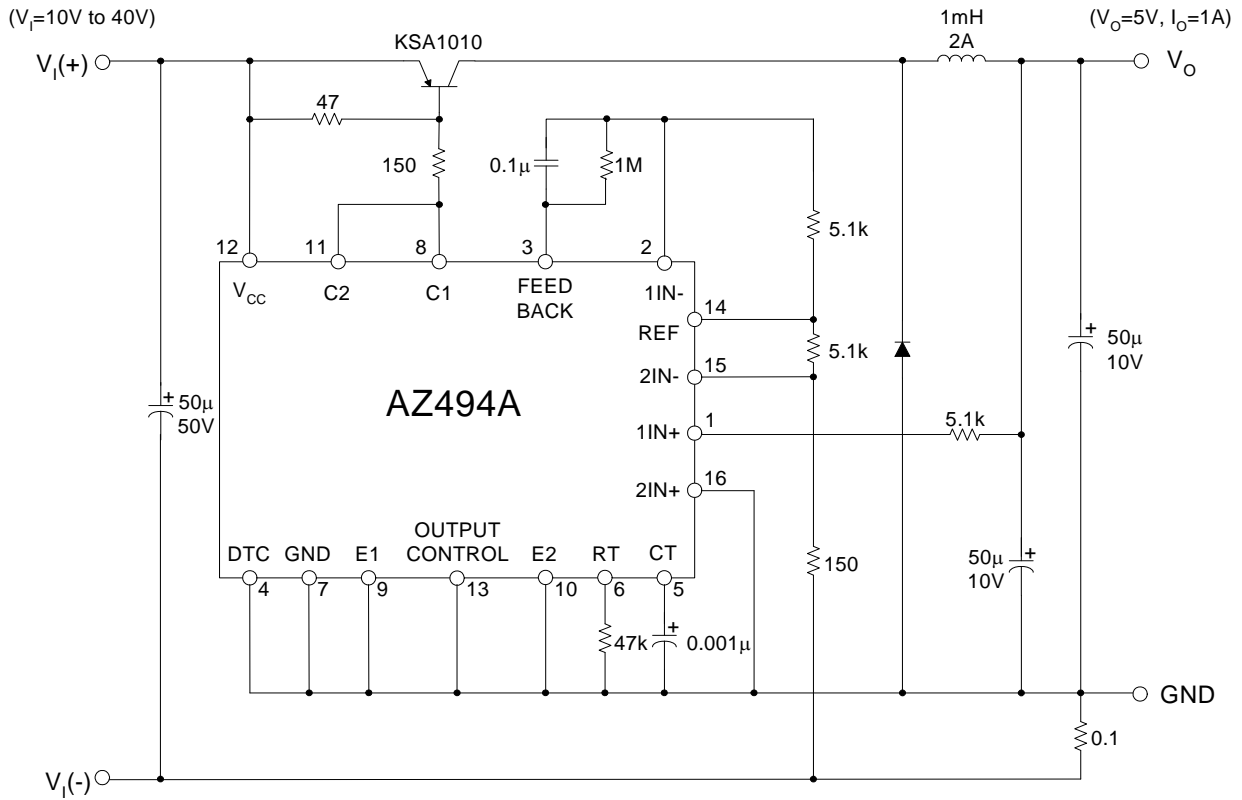

Figure 10. Pulse Width Modulated Step-Down Converter



**Mechanical Dimensions**

**SOIC-16**

**Unit: mm(inch)**

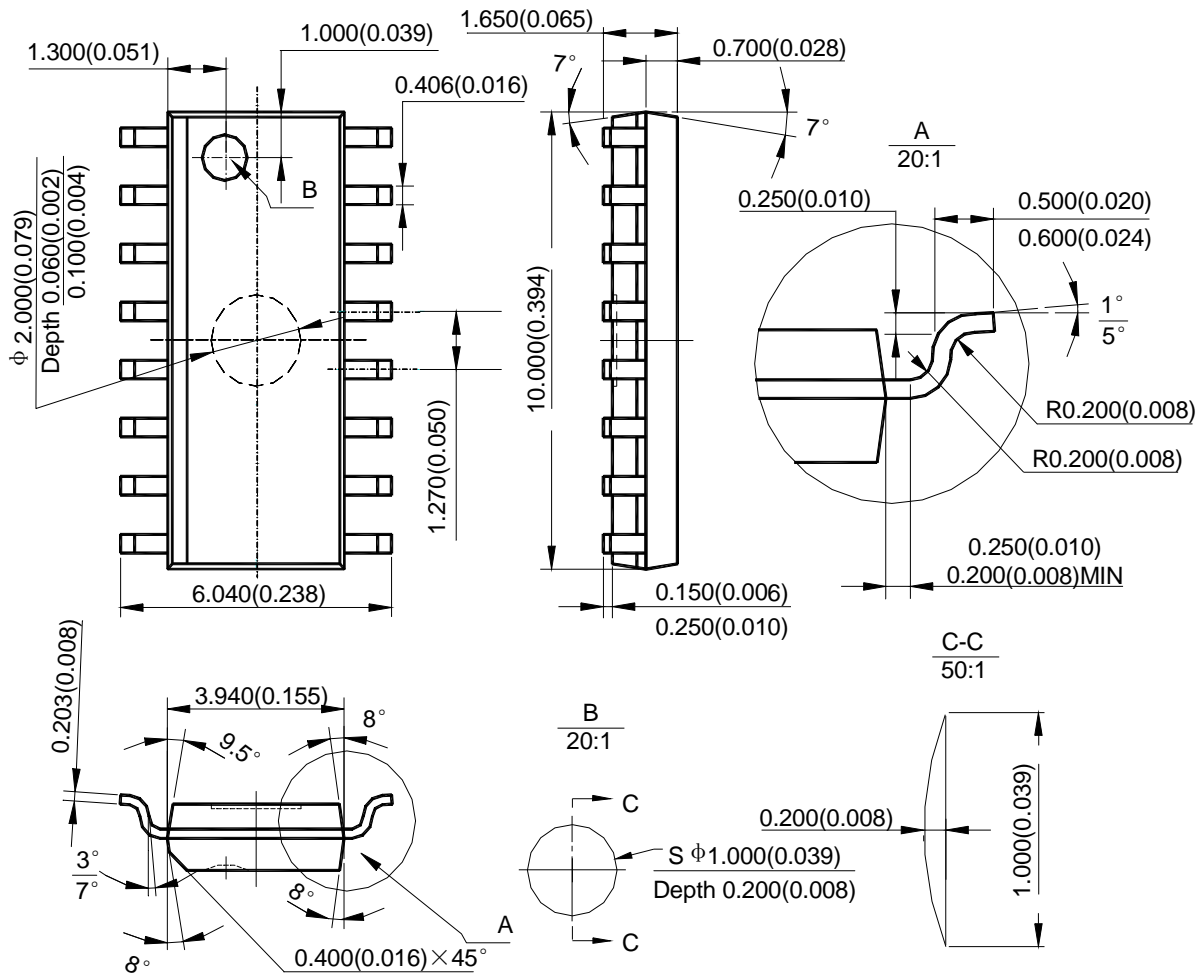



**PULSE-WIDTH-MODULATION CONTROL CIRCUITS**

**AZ494A/C**

**Mechanical Dimensions (Continued)**

**DIP-16**

**Unit: mm(inch)**

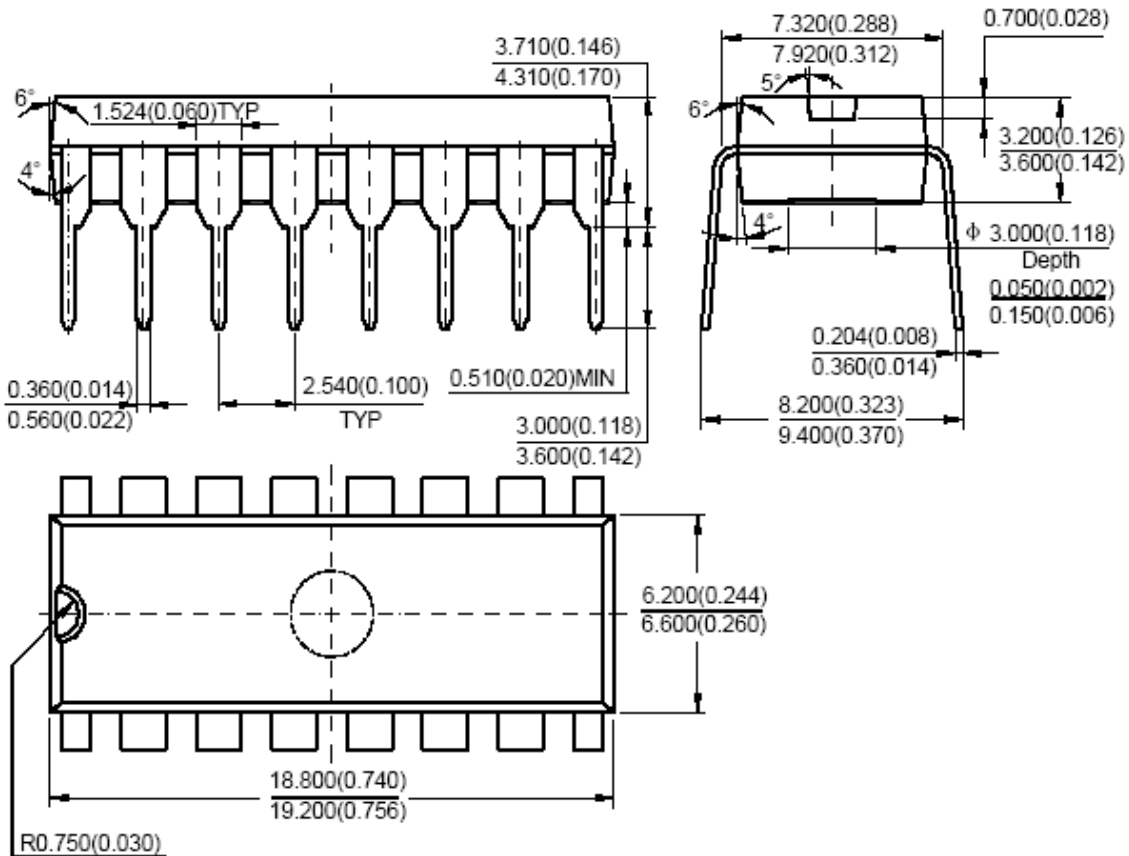



## **BCD Semiconductor Manufacturing Limited**

<http://www.bcdsemi.com>

### **IMPORTANT NOTICE**

BCD Semiconductor Manufacturing Limited reserves the right to make changes without further notice to any products or specifications herein. BCD Semiconductor Manufacturing Limited does not assume any responsibility for use of any its products for any particular purpose, nor does BCD Semiconductor Manufacturing Limited assume any liability arising out of the application or use of any its products or circuits. BCD Semiconductor Manufacturing Limited does not convey any license under its patent rights or other rights nor the rights of others.

---

#### **MAIN SITE**

##### **- Headquarters**

##### **BCD Semiconductor Manufacturing Limited**

No. 1600, Zi Xing Road, Shanghai Zizhu Science-based Industrial Park, 200241, China  
Tel: +86-21-24162266, Fax: +86-21-24162277

##### **- Wafer Fab**

##### **Shanghai SIM-BCD Semiconductor Manufacturing Co., Ltd.**

800 Yi Shan Road, Shanghai 200233, China  
Tel: +86-21-6485 1491, Fax: +86-21-5450 0008

#### **REGIONAL SALES OFFICE**

##### **Shenzhen Office**

**Shanghai SIM-BCD Semiconductor Manufacturing Co., Ltd., Shenzhen Office**  
Room E, 5F, Noble Center, No.1006, 3rd Fuzhong Road, Futian District, Shenzhen,  
518026, China  
Tel: +86-755-8826 7951  
Fax: +86-755-8826 7865

##### **Taiwan Office**

**BCD Semiconductor (Taiwan) Company Limited**  
4F, 298-1, Rui Guang Road, Nei-Hu District, Taipei,  
Taiwan  
Tel: +886-2-2656 2808  
Fax: +886-2-2656 2806

##### **USA Office**

**BCD Semiconductor Corp.**  
30920 Huntwood Ave. Hayward,  
CA 94544, USA  
Tel : +1-510-324-2988  
Fax: +1-510-324-2788